

Manufactured in Italy, Vertex, the premier brand of OEM replacement pistons, is the OEM supplier to KTM and numerous European motorcycle and go-kart manufacturers. Vertex offers enthusiasts state-of-the-art, high-quality pistons for nearly any powersport use from motorcycles and ATVs to marine and karting. Manufactured to the highest standards in Japan, Vertex's piston rings are produced by the OEM suppliers so that they are direct OEM replacements. Vertex is the choice of those who truly seek the optimum in powersport performance in any application.



I pistoni Vertex sono interamente prodotti in Italia e sono primo equipaggiamento di numerose case europee produttrici di moto e go-kart, con in evidenza KTM. Vertex offre agli esperti di elaborazioni, pistoni di alta qualità tecnologicamente ai vertici del settore, utilizzabili per qualsiasi applicazione nei settori: moto (strada e fuoristrada), Quad, ATV, go-kart e fuoribordo, dove il massimo della potenza è un requisito imprescindibile. I segmenti assemblati da Vertex sui propri pistoni, sono fabbricati in Giappone secondo i massimi standard del settore dai fornitori OEM delle maggiori case giapponesi di moto, sono quindi intercambiabili con i prodotti originali. Vertex è la scelta numero uno di chi esige il massimo delle prestazioni nel mondo degli sport motoristici, per qualsiasi applicazione.

Cast vs. Forged What's better and why:

Vertex Two-stroke Pistons

Because of a cast piston's ability to contain higher silicon content compared to forged pistons, and because two-strokes have lower cylinder pressures when compared to four-strokes, cast pistons are ideal for two-stroke engines. Vertex pistons are gravity cast from an aluminum alloy with 18% silicon content. Silicon is important because:

- It decreases thermal expansion, which changes the geometry after the piston reaches operating temperature. With low thermal expansion characteristics, Vertex pistons can be run at tighter tolerances compared with forged pistons. This creates better power and performance, also making them less susceptible to rattling or breaking.
- Silicon gives the pistons better wear characteristics and prolongs piston life by decreasing wear on the piston skirt.



Fuso o forgiato Cosa è meglio e perché:

Pistoni Vertex per motori a 2 tempi

Poiché un pistone realizzato tramite fusione può avere un contenuto maggiore di silicio rispetto al forgiato, e poiché nei motori a 2 tempi le pressioni nei cilindri sono inferiori rispetto alle versioni a 4 tempi, i pistoni fusi sono la soluzione ideale per questa applicazione. I pistoni Vertex 2 tempi, sono realizzati per fusione a gravità da una lega di alluminio con contenuto di silicio pari al 18%. Il contenuto di silicio è importante perché:

- Riduce l'espansione termica che determina il cambiamento della geometria del profilo dopo che il pistone raggiunge la temperatura d'esercizio. Grazie a caratteristiche di espansione termica ridotta, i pistoni Vertex per motori 2 tempi, possono funzionare con tolleranze più ristrette rispetto ai pistoni forgiati. Ciò garantisce un sensibile incremento in termini di potenza e durata, con la sicurezza di un funzionamento più silenzioso e senza eventuali rotture.
- La presenza dell'alto contenuto di silicio permette anche una migliore resistenza all'usura e prolunga quindi la vita del pistone senza cali di prestazioni.



Vertex Four-stroke Pistons

Four-stroke engines have much higher cylinder pressures when compared to two-strokes and are generally manufactured from forgings. To handle the internal pressures of a four-stroke engine, Vertex's four-stroke pistons are forged from the highest quality 2618 aluminum alloy for superior strength and durability. Vertex uses unique piston profiles and compression ratios, offered in A, B, C and D sizes, to maximize power and performance while reducing blow-by and oil consumption.

Pistoni Vertex per motori a 4 tempi

I motori a 4 tempi hanno pressioni nei cilindri molto più elevate rispetto ai 2 tempi e generalmente i pistoni da equipaggiarli, vengono prodotti tramite forgiatura a caldo. I pistoni Vertex per motori 4 tempi vengono forgiati a caldo dalla lega per uso aeronautico 2618, un prodotto di altissima qualità che garantisce doti superiori di resistenza e durata. Vertex applica poi profili esclusivi e conformazioni di testa derivati dallo sviluppo fatto con i teams, il tutto al fine di ottimizzare al massimo potenza, coppia e prestazioni in generale, riducendo al contempo consumo d'olio e trafilamento (blow by).

Aiding in the break-in process and reducing wear, every Vertex piston has a Molybdenum Disulphide (MOS2) coating on the piston skirt.

Per facilitare il rodaggio e ridurre l'usura, ogni pistone Vertex è provvisto di rivestimento in bisolfuro di molibdeno (MOS2) sull'intero corpo del pistone.

Vertex Wrist Pin Features:

- KTM four-stroke wrist pins are DLC coated.
- Case hardened wrist pins are used with all Vertex pistons.
- Nitride coated pins are normally used for high performance four-stroke engines utilizing a bronze bushing or with engines using a steel connecting rod without bearings. This hardened surface is highly wear resistant and provides anti-galling properties.
- Nitriding is a highly specialized surface treatment that produces a highly wear resistant surface. The significant advantage of nitriding is that the surface hardness is developed without quenching and the attendant distortion problems with case hardening. Finishing operations can be eliminated or held to a minimum.

Spinotti Vertex:

- Gli spinotti Vertex, sono normalmente prodotti in acciaio legato con trattamento di cementazione. In aggiunta, esistono le seguenti varianti per i rispettivi campi di applicazione:
- Spinotti nitruati che sono normalmente utilizzati per motori a quattro tempi a elevate prestazioni, che hanno la biella in acciaio con o senza bronzina. La superficie nitruata è altamente resistente all'usura e fornisce caratteristiche antigrippaggio.
- Gli spinotti per i pistoni destinati a motori 4 tempi KTM, sono provvisti di rivestimento in DLC.



Vertex Piston Rings

Vertex's latest generation two-stroke and four-stroke piston rings are nitride coated or chrome plated, increasing wear resistance and extending durability. Vertex piston rings are exact OEM replacements.

Segmenti Vertex

I segmenti Vertex di ultimissima generazione per motori a 2 e 4 tempi sono realizzati in acciaio con trattamenti di nitrurazione o cromatura. Il tutto per aumentare la resistenza all'usura e per migliorare la durata di vita. I segmenti per pistoni Vertex sono intercambiabili con i corrispettivi prodotti OEM.

All Vertex Pistons Feature:

- Standard pistons and components are OEM replacements.
- Kits include piston, rings, wrist pin and circlips.
- All pistons are heat treated with a T-5 or T-6 hardening and tempering cycle.
- Replacement rings are sold individually.

All Vertex Pistons Feature:

- I pistoni e i componenti standard sono intercambiabili con i rispettivi prodotti OEM.
- I kit comprendono pistone, segmenti, spinotto e anellini.
- Tutti i pistoni sono sottoposti a trattamento termico con ciclo di bonifica T5 o T6.
- I segmenti di ricambio vengono anche venduti singolarmente.



CODICE CODE	DESCRIZIONE DESCRIPTION
Replica	Pistone fuso in forma originale <i>Cast piston in original OE form</i>
Race	Pistone fuso sviluppato con tecnologia Vertex <i>Cast piston developed with Vertex know-how</i>
Pro	Pistone forgiato <i>Forged piston</i>
Replica BB	Pistone fuso in forma originale per cilindro maggiorato <i>Cast piston in original OE form for big bore cylinder</i>
Pro Replica	Pistone forgiato in forma originale <i>Forged piston in original OE form</i>
Pro BB	Pistone forgiato in forma originale per cilindro maggiorato <i>Forged piston in original OE form for big bore cylinder</i>
Pro Race	Pistone forgiato sviluppato con tecnologia Vertex <i>Forged piston developed with Vertex know-how</i>
Pro HC	Pistone forgiato sviluppato con tecnologia Vertex ed alta compressione <i>Forged piston developed with Vertex know-how and high compression</i>



OFF ROAD - ATV PISTONS

Pistoni fuoristrada-Atv pag. 7

1

ON ROAD-SCOOTERS PISTONS

Pistoni strada - Scooters pag. 37

2

GO - KART PISTONS

Pistoni Go-Kart pag. 63

3

PERSONAL WATERCRAFT PISTONS

Pistoni Moto d'Acqua pag. 69

4

CYLINDER KITS

Kit Cilindri pag. 73

5

ENGINE VALVES

Valvole Motore pag. 75

6

CLUTCH PLATES

Dischi Frizione pag. 79

7

INNER CLUTCH HUBS

Mozzi Interni Frizione pag. 87

8

BEARINGS

Gabbie a Rulli pag. 89

9

GASKETS SETS

Set Guarnizioni pag. 95

10

CAMCHAINS

Catene di Distribuzione pag. 101

11









Modello Model	CC	Anni Years	Cilindro Cylinder (mm)	Versione Version	Pistone Completo / Complete Piston			Set Segmenti / Ring Set		Spinotto / Wrist Pin		Anellino / Circlip	
					Ø mm	Codice Code	€	Codice Code	€	Codice Code	€	Codice Code	€
BETAMOTOR													
MOTO 2 TEMPI - MOTORCYCLES 2 STROKE													
RK6 Enduro, K50 Trial, ST50	50	1995-97	39,50	Replica	39,46	22171A	40,61	53012503950	13,57	715036	2,25	72065	0,33
					39,47	22171B							
					39,48	22171C							
					39,49	22171D							
					39,50	22171E							
39,51	22171F												
RK6 Enduro	50	1995-97	39,50	Race	39,46	22367A*	40,61	53012503950	13,57	715036	2,25	72065	0,33
					39,47	22367B*							
					39,48	22367C*							
					39,49	22367D*							
RK6 Enduro	50	1998-02	39,50	Replica	39,46	22525AB	40,61	53012503950	13,57	715036	2,25	72053	0,33
					39,47	22525CD							
					39,48	22525EF							
					39,49	22525GH							
Tecno, Alp, Trial	250	1995-97	72,50	Replica	72,451	22176A	147,56	53515007250	18,22	711125	4,90	72047	0,33
					72,457	22176B							
					72,463	22176C							
					72,469	22176D							
Zero 270, Trial	270		76,00	Replica	75,951	22436A	152,62	53515007600	18,22	711125	4,90	72047	0,33
					75,957	22436B							
					75,963	22436C							
					75,969	22436D							
MOTO 4 TEMPI - MOTORCYCLES 4 STROKE													
RR125 RE ALP Motard Urban	125	2006-09	54,00	Replica	53,97	23349	108,16	590354000001	38,03	715262	2,69	72049	0,33
					+0,25	23349025							
					+0,50	23349050							
					+2,00	23349200							
RR250	250	2005-07	75,00	Pro Replica	74,95	22978A	152,26	590275000001	32,56	711140	7,93	72075	0,33
					74,96	22978B							
					74,97	22978C							
RR250	250	2005-07	75,00	Pro-HC	74,95	22980A	171,26	590275000001	32,56	711140	7,93	72075	0,33
					74,96	22980B							
					74,97	22980C							
RR250 Big Bore	280	2005-07	77,00	Pro-BB	76,96	22979200	171,26	590277000002	32,56	711140	7,93	72075	0,33
RR450 compr. 11:1	450	2005-09	89,00	Replica	88,94	23329A	166,58	590289000001	42,49	715108	5,89	72075	0,33
					88,95	23329B							
					88,96	23329C							
RR450 compr. 12:1	450	2005-09	89,00	Pro-HC	88,94	23340A	177,29	590289000001	42,49	715108	5,89	72075	0,33
					88,95	23340B							
					88,96	23340C							
RR525 compr. 11:1	510	2005-09	95,00	Pro Replica	94,93	22942A	176,96	590295000001	35,31	711140	7,93	72075	0,33
					94,94	22942B							
					94,95	22942C							
					94,96	22942D							
RR525	510	2005-09	95,00	Pro-HC	94,93	22969A	193,09	590295000001	35,31	711140	7,93	72075	0,33
					94,94	22969B							
					94,95	22969C							
					94,96	22969D							
RR525 Big Bore	530	2005-08	97,00	Pro-BB	96,96	22958200	193,09	590297000001	49,11	711140	7,93	72075	0,33
RR525 Big Bore	540	2005-08	98,00	Pro-BB	97,96	22958300	193,09	590298000002	49,11	711140	7,93	72075	0,33

* Fino ad esaurimento scorte / Limited stock



Modello Model	CC	Anni Years	Cilindro Cylinder (mm)	Versione Version	Pistone Completo / Complete Piston			Set Segmenti / Ring Set		Spinotto / Wrist Pin		Anellino / Circlip	
					Ø mm	Codice Code	€	Codice Code	€	Codice Code	€	Codice Code	€
CAGIVA													
MOTO 2 TEMPI - MOTORCYCLES 2 STROKE													
Cross 125	125	1984-88	56,00	Replica	55,96	21600A	75,81	53010005600	16,01	711121	4,90	72027	0,33
					55,97	21600B							
					55,98	21600C							
					55,99	21600D							
					56,00	21600E							
					56,01	21600F							
					56,02	21600G							
Cross 125	125	1988-91	56,00	Replica	55,96	21889A	77,35	53010005600	16,01	711121	4,90	72027	0,33
					55,97	21889B							
					55,98	21889C							
					55,99	21889D							
					56,00	21889E							
Cross 250	250	1985-91	70,00	Replica	69,950	21757A*	113,11	53010007000	23,18	711125	4,90	72048	0,33
					69,950	21757AB							
					69,955	21757B*							
					69,960	21757CD							
					69,960	21757C*							
					69,965	21757D*							
					69,970	21757EF							
					69,970	21757E*							
69,975	21757F*												
FANTIC MOTOR													
MOTO 2 TEMPI - MOTORCYCLES 2 STROKE													
Trial 200	200		69,00	Replica	68,95	21886A*	140,40	53515006900 52715006900	19,83 9,11	711117	5,04 6,07 7,11 8,14	72060	0,33
					68,96	21886B*							
					68,97	21886C*							
					68,98	21886D*							
Trial Section 250	250		74,00	Replica	73,957	22435A	145,58	53515007400 52715007400	19,83 9,11	711117	9,18 10,21 11,25 12,28	72060	0,33
					73,964	22435B							
					73,971	22435C							
					73,978	22435D							
MOTO 4 TEMPI - MOTORCYCLES 4 STROKE													
Caballero	125	2007-09	54,00	Replica	53,97	23349	108,16	590354000001 590354250001 590354500001 590356000001	38,03	715262	2,69	72049	0,33
					+0,25	23349025							
					+0,50	23349050							
					+2,00	23349200							
Caballero TZ170 Liquid Cooled Raffr.Liquido	125	2008-10	52,00	H.C. Race	51,96	23516A	108,16	590352000001	38,03	715029	4,51	72050	0,33
					51,97	23516B							
					51,98	23516C							
GAS GAS													
MOTO 2 TEMPI - MOTORCYCLES 2 STROKE													
TXT125	125	2002	54,00	Replica	53,95	22766A	101,48	53010005400 53010005400	16,01 16,01	715130	2,69	72055	0,33
					53,96	22766B							
					53,97	22766C							
					53,98	22766D							
					53,99	22766E							
EC MX 125	125	2003-10	54,00	Replica	53,95	23195A	107,27	53010005400	16,01	711127	5,04	72071	0,33
					53,96	23195B							
					53,97	23195C							
					53,98	23195D							
					53,99	23195E							

* Fino ad esaurimento scorte / Limited stock



Modello Model	CC	Anni Years	Cilindro Cylinder (mm)	Versione Version	Pistone Completo / Complete Piston			Set Segmenti / Ring Set		Spinotto / Wrist Pin		Anellino / Circlip	
					Ø mm	Codice Code	€	Codice Code	€	Codice Code	€	Codice Code	€
GAS GAS													
MOTO 2 TEMPI - MOTORCYCLES 2 STROKE													
HALLEY 125 HALLEY SM 125	125	2003-10	54,00	Replica	53,95	23195A	107,27	53010005400	16,01	711127	5,04	72071	0,33
					53,96	23195B							
					53,97	23195C							
					53,98	23195D							
					53,99	23195E							
TXT 200	200	2002	64,00	Replica	63,95	22767A	143,22	53010006400 53010006400	18,22 18,22	715258	2,58	72058	0,33
					63,96	22767B							
					63,97	22767C							
					63,98	22767D							
					63,99	22767E							
					64,00	22767F							
					64,01	22767G							
EC 250	250	2002-07	66,40	Replica	66,33	23249A	124,14	53010006640 53010006640	23,18 23,18	715372	4,51	72074	0,33
					66,34	23249B							
					66,35	23249C							
					66,36	23249D							
EC 300	300	2002-07	72,00	Replica	71,94	22981A	149,18	53010007200 53010007200	23,18 23,18	715372	4,51	72074	0,33
					71,95	22981B							
					71,96	22981C							
					71,97	22981D							
MOTO 4 TEMPI - MOTORCYCLES 4 STROKE													
FSE450	450	2003-04	95,00	Pro Replica	94,95	22953A	160,43	590395000001	32,01	711140	7,93	72075	0,33
					94,96	22953B							
					94,97	22953C							
					94,98	22953D							
ATV 2 TEMPI - ATV 2 STROKE													
Wild HP300	300	2002-07	72,00	Replica	71,94	22981A	149,18	53010007200 53010007200	23,18 23,18	715372	4,51	72074	0,33
					71,95	22981B							
					71,96	22981C							
					71,97	22981D							
HM MOTO													
MOTO 2 TEMPI - MOTORCYCLES 2 STROKE													
Minicross 50	50		39,00	Replica	38,95	22783A	41,20	53010003900	12,48	715034	2,25	72053	0,33
					38,96	22783B							
					38,97	22783C							
					38,98	22783D							
					38,99	22783E							
CRE50	50	1995-04	40,31	Replica	40,25	22088A	39,14	53015004030 52715004030	5,42 2,54	715038	2,25 3,29 4,32 5,36 6,39 7,43 8,46	72025	0,33
					40,26	22088B							
					40,27	22088C							
					40,28	22088D							
					40,29	22088E							
					40,31	22088F							
					40,31	22088G							
CRE260	260	1989-00	68,00	Replica	67,94	22227A	141,34	53012006800 53012006800	23,18 23,18	715372	4,51	72074	0,33
					67,95	22227B							
					67,96	22227C							
					67,97	22227D							
MOTO 4 TEMPI - MOTORCYCLES 4 STROKE													
CR F 125X CRM F 125X Liquid cooled Raffr.Liquido	125	2009-10	52,00	H.C. Race	51,96	23516A	108,16	590352000001	38,03	715029	4,51	72050	0,33
					51,97	23516B							
					51,98	23516C							



Modello Model	CC	Anni Years	Cilindro Cylinder (mm)	Versione Version	Pistone Completo / Complete Piston			Set Segmenti / Ring Set		Spinotto / Wrist Pin		Anellino / Circlip	
					Ø mm	Codice Code	€	Codice Code	€	Codice Code	€	Codice Code	€
HONDA													
MOTO 2 TEMPI - MOTORCYCLES 2 STROKE													
CR80	80	1990-99	46,00	Replica	45,94	22446A	71,41	53010004600	13,80	711137	5,04	72050	0,33
					45,95	22446B							
					45,96	22446C							
					45,97	22446D							
CR80 USA	82	1990-02	47,00	Replica	46,94	22499A	71,41	53009804700	14,46	715378	3,75	72050	0,33
					46,95	22499B							
					46,96	22499C							
					46,97	22499D							
CR85	85	2003-07	47,50	Replica	47,44	22863A	71,41	53010004750	13,80	715378	3,75	72050	0,33
					47,45	22863B							
					47,46	22863C							
					47,47	22863D							
CR85	85	2003-07	49,50	Pro-BB	49,45	22866200	83,31	53010004950	14,35	715378	3,75	72050	0,33
CR125	125	1990-91	54,00	Replica	53,93	22151A	97,20	53010005400	16,01	711127	5,04	72071	0,33
					53,94	22151B							
					53,95	22151C							
					53,96	22151D							
CR125	125	1992-99	54,00	Replica	53,93	22189A*	97,20	53010005400	16,01	711127	5,04	72071	0,33
					53,94	22189B							
					53,95	22189C							
					53,96	22189D							
CR125 without port senza feritoia	125	1992-99	54,00	Race	53,97	22189E	97,20	53010005400	16,01	711127	5,04	72071	0,33
					53,93	22190A							
					53,94	22190B							
					53,95	22190C							
CR125	125	1992-99	54,00	Race	53,96	22190D	107,27	53010005400	16,01	711127	5,04	72071	0,33
					53,97	22190E							
					53,93	22358A*							
					53,94	22358B							
CR125	125	1992-03	54,00	Pro-Race	53,95	22358C	115,57	53010005400	16,01	711127	5,04	72071	0,33
					53,96	22358D							
					53,97	22358E							
					53,93	22548A							
CR-CRE125	125	2000-03	54,00	Replica	53,94	22548B	97,20	53010005400	16,01	711127	5,04	72071	0,33
					53,95	22548C							
					53,96	22548D							
					53,97	22548E							
CR-CRE125 without port senza feritoia	125	2000-03	54,00	Race	53,92	22685A	97,20	53010005400	16,01	711127	5,04	72071	0,33
					53,93	22685B							
					53,94	22685C							
					53,95	22685D							
CR-CRE125	125	2000-03	54,00	Race	53,96	22685E	107,27	53010005400	16,01	711127	5,04	72071	0,33
					53,97	22685F							
					53,92	22687A							
					53,93	22687B							
CR-CRE125	125	2000-03	54,00	Race	53,94	22687C	97,20	53010005400	16,01	711127	5,04	72071	0,33
					53,95	22687D							
					53,96	22687E							
					53,97	22687F*							
CR-CRE125	125	2000-03	54,00	Race	53,92	22689A*	107,27	53010005400	16,01	711127	5,04	72071	0,33
					53,93	22689B							
					53,94	22689C							
					53,95	22689D							
CR-CRE125	125	2000-03	54,00	Race	53,96	22689E	107,27	53010005400	16,01	711127	5,04	72071	0,33
					53,97	22689F*							

* Fino ad esaurimento scorte / Limited stock



Modello Model	CC	Anni Years	Cilindro Cylinder (mm)	Versione Version	Pistone Completo / Complete Piston			Set Segmenti / Ring Set		Spinotto / Wrist Pin		Anellino / Circlip		
					Ø mm	Codice Code	€	Codice Code	€	Codice Code	€	Codice Code	€	
HONDA														
MOTO 2 TEMPI - MOTORCYCLES 2 STROKE														
CR-CRE125	125	2004	54,00	Replica	53,92	22995A	97,20	53010005400	16,01	711127	5,04	72071	0,33	
					53,93	22995B								
					53,94	22995C								
					53,95	22995D								
					53,96	22995E								
53,97	22995F*													
CR-CRE125	125	2005-07	54,00	Replica	53,92	23140A	97,20	53010005400	16,01	711127	5,04	72071	0,33	
					53,93	23140B								
					53,94	23140C								
					53,95	23140D								
					53,96	23140E								
53,97	23140F*													
CR-CRE125	125	2004-07	54,00	Race	53,92	22996A	107,27	53010005400	16,01	711127	5,04	72071	0,33	
					53,93	22996B								
					53,94	22996C								
					53,95	22996D								
					53,96	22996E								
53,97	22996F*													
CR-CRE125	125	2004-07	54,00	Pro-Race	53,92	22997A	115,57	53010005400	16,01	711127	5,04	72071	0,33	
					53,93	22997B								
					53,94	22997C								
					53,95	22997D								
					53,96	22997E								
53,97	22997F*													
CR-CRE 144	144	2004-07	57,00	Pro-Race	56,95	23265A	115,57	53010005700	16,01	715389	6,97	72071	0,33	
					56,96	23265B								
CR-CRE250	250	1989-94	66,40	Replica	66,34	22153A	119,42	53010006640	23,18	715372	4,51	72074	0,33	
					66,35	22153B		53010006640						23,18
					66,36	22153C								
					66,37	22153D								
CR-CRE250	250	1995-96	66,40	Replica	66,34	22387A	119,42	53010006640	23,18	715372	4,51	72074	0,33	
					66,35	22387B		53010006640						
					66,36	22387C								
					66,37	22387D								
CR-CRE250	250	1997-98	66,40	Replica	66,34	22454A*	119,42	53010006640	23,18	715372	4,51	72074	0,33	
					66,35	22454B*		53010006640						
					66,36	22454C*								
					66,37	22454D*								
CR-CRE250	250	1997-01	66,40	Race	66,34	22455A	119,42	53010006640	23,18	715372	4,51	72074	0,33	
					66,35	22455B								
					66,36	22455C								
					66,37	22455D								
CR-CRE250	250	1997-01	66,40	Replica	66,34	22581A	119,42	53010006640	23,18	715372	4,51	72074	0,33	
					66,35	22581B		53010006640						
					66,36	22581C								
					66,37	22581D								
CR-CRE250	250	1997-01	66,40	Pro-Race	66,34	22653A	132,16	53010006640	23,18	715372	4,51	72074	0,33	
					66,35	22653B								
					66,36	22653C								
					66,37	22653D								
CR-CRE250	250	2002-04	66,40	Replica	66,34	22809A	119,42	53010006640	23,18	715372	4,51	72074	0,33	
					66,35	22809B		53010006640						
					66,36	22809C								
					66,37	22809D								

* Fino ad esaurimento scorte / Limited stock



Modello Model	CC	Anni Years	Cilindro Cylinder (mm)	Versione Version	Pistone Completo / Complete Piston			Set Segmenti / Ring Set		Spinotto / Wrist Pin		Anellino / Circlip	
					Ø mm	Codice Code	€	Codice Code	€	Codice Code	€	Codice Code	€
HONDA													
MOTO 2 TEMPI - MOTORCYCLES 2 STROKE													
CR-CRE250	250	2002-04	66,40	Race	66,34	22810A	119,42	53010006640	23,18	715372	4,51	72074	0,33
					66,35	22810B							
					66,36	22810C							
					66,37	22810D							
CR-CRE250	250	2002-04	66,40	Pro-Race	66,34	22811A	132,16	53010006640	23,18	715372	4,51	72074	0,33
					66,35	22811B							
					66,36	22811C							
					66,37	22811D							
CR-CRE250	250	2005-07	66,40	Replica	66,34	23133A	119,42	53010006640	23,18	715372	4,51	72074	0,33
					66,35	23133B							
					66,36	23133C							
					66,37	23133D							
CR-CRE250	250	2005-07	66,40	Race	66,34	23137A	119,42	53010006640	23,18	715372	4,51	72074	0,33
					66,35	23137B		53010006640					
					66,36	23137C							
					66,37	23137D							
CR-CRE250	250	2005-07	66,40	Pro-Race	66,34	23138A	132,16	53010006640	23,18	715372	4,51	72074	0,33
					66,35	23138B							
					66,36	23138C							
					66,37	23138D							
CR-CRE500	500	1985-04	89,00	Replica	88,95	22447	132,76	53315008900	16,55	711134	8,36	72073	0,33
					+0,50	22447050		53315008950	16,55				
					+1,00	22447100		53315008950	16,55				
					+1,50	22447150		53315009000	16,55				
					+2,00	22447200		53315009000	16,55				
								53315009050	16,55				
								53315009050	16,55				
CR-CRE500	500	1985-04	89,00	Race	88,95	22458*	139,26	53315008900	16,55	711134	8,36	72073	0,33
					+0,50	22458050*		53315008950	16,55				
					+1,00	22458100*		53315009000	16,55				
					+1,50	22458150*		53315009050	16,55				
					+2,00	22458200*		53315009100	16,55				
								53315009100	16,55				
MOTO 4 TEMPI - MOTORCYCLES 4 STROKE													
CRF150R compr. 11.7:1	150	2007-09	66,00	Pro Replica	65,97	23302A	125,34	590266000001	39,17	715029	4,51	72093	0,33
					65,98	23302B							
					65,99	23302C							
CRF150R compr. 12.2:1	150	2007-09	66,00	Pro-HC	65,97	23304A	136,58	590266000001	39,17	715029	4,51	72093	0,33
					65,98	23304B							
					65,99	23304C							
CRF150R Big Bore compr. 11,7:1	160	2007-09	68,00	Pro-BB	67,97	23520A	145,15	590268000001	43,59	715029	4,51	72093	0,33
					67,98	23520B							
					67,99	23520C							
CRF150R Big Bore	180	2007-09	72,00	Pro-BB	71,97	23309600	145,15	590272000002	43,59	715084	4,51	72093	0,33
CRF250R CRE 250X compr. 12.9:1	250	2004-07	78,00	Pro Replica	77,95	22983A	149,18	590278000002	43,59	715380	8,04	72055	0,33
		2004-11			77,96	22983B							
		77,97			22983C								
		77,98			22983D								
CRF250R CRE250X Compr. 13.4:1	250	2004-07	78,00	Pro-HC	77,95	23113A	160,88	590278000002	43,59	715380	8,04	72055	0,33
		2004-11			77,96	23113B							
		77,97			23113C								
		77,98			23113D								

* Fino ad esaurimento scorte / Limited stock



Modello Model	CC	Anni Years	Cilindro Cylinder (mm)	Versione Version	Pistone Completo / Complete Piston			Set Segmenti / Ring Set		Spinotto / Wrist Pin		Anellino / Circlip	
					Ø mm	Codice Code	€	Codice Code	€	Codice Code	€	Codice Code	€
HONDA													
MOTO 4 TEMPI - MOTORCYCLES 4 STROKE													
CRF250R compr. 13.0:1	250	2008-09	78,00	Pro Replica	77,95	23443A	149,18	590278000002	43,59	715380	8,04	72055	0,33
					77,96	23443B							
					77,97	23443C							
					77,98	23443D							
CRF250R compr. 13.5:1	250	2008-09	78,00	Pro-HC	77,95	23444A	160,88	590278000002	43,59	715380	8,04	72055	0,33
					77,96	23444B							
					77,97	23444C							
					77,98	23444D							
CRF250R Compr.13.7:1	250	2009	78,00	Pro-HC	77,95	23529A	160,88	590278000002	43,59	715380	8,04	72055	0,33
					77,96	23529B							
					77,97	23529C							
					77,98	23529D							
CRF250R compr. 13.2:1	250	2010-11	76,80	Pro Replica	76,76	23510A	149,18	590276800001	43,59	715380	8,04	72055	0,33
					76,77	23510B							
					76,78	23510C							
					76,79	23510D							
CRF250R compr. 14.1:1	250	2010-11	76,80	Pro-HC	76,76	23561A	160,88	590276800001	43,59	715380	8,04	72055	0,33
					76,77	23561B							
					76,78	23561C							
					76,79	23561D							
CRF250R Big Bore compr.13.5:1	265	2010-11	79,00	Pro-HC BB	78,96	23589A	160,88	590279000001	43,59	715380	8,04	72055	0,33
					78,97	23589B							
					78,98	23589C							
CRF250R CRF250X Big Bore compr.13.0:1	256	2004-09 2004-10	79,00	Pro-BB	78,96	23461A	160,88	590279000001	43,59	715380	8,04	72055	0,33
					78,97	23461B							
					78,98	23461C							
CRF250R Big Bore NEW Compr 13,2:1	270	2010-11	80,00	BB	79,96	23653A	160,88	590280000001	43,59	715380	8,04	72055	0,33
					79,97	23653B							
					79,98	23653C							
CRF250R CRE F 250X Big Bore	262	2004-09 2004-11	80,00	Pro-BB	79,96	22983200	160,88	590280000001	43,59	715380	8,04	72055	0,33
CRF250R CRF250X Big Bore compr.13.0:1	270	2004-09 2004-11	81,00	Pro-BB	80,96	23535A	160,88	590281000001	43,59	715380	8,04	72055	0,33
					80,97	23535B							
					80,98	23535C							
CRF250R CRE250X Big Bore	290	2004-09 2004-11	84,00	Pro-BB	83,96	23232600	160,88	590284000002	43,59	715380	8,04	72055	0,33
CRF250R CRE250X Big Bore	300	2004-09 2004-11	85,00	Pro-BB	84,96	23318700	160,88	590285000002	43,59	715380	8,04	72055	0,33
XR400R compr.9,3:1	400	1996-04	85,00	Pro Replica	STD	23162	124,46	590385000001	27,03	711163	8,04	72075	0,33
					+0,50	23162050		590385500001					
					+1,00	23162100		590386000001					
CRF450R CRE450X compr. 11.5:1	450	2002-03	96,00	Pro Replica	95,95	22814A	160,26	590296000001	43,59	711144	8,04	72090	0,33
					95,96	22814B							
					95,97	22814C							
					95,98	22814D							
CRF450R CRE450X compr. 12.5:1	450	2002-08 2002-11	96,00	Pro-HC	95,95	22900A	172,68	590296000001	43,59	711144	8,04	72090	0,33
					95,96	22900B							
					95,97	22900C							
					95,98	22900D							
					95,99	22900E							
96,00	22900F*												
CRF450R CRE450X compr. 12.1:1	450	2004-08 2004-11	96,00	Pro Replica	95,95	23003A	160,66	590296000001	43,59	711144	8,04	72090	0,33
					95,96	23003B							
					95,97	23003C							
					95,98	23003D							
					95,99	23003E							
96,00	23003F*												

* Fino ad esaurimento scorte / Limited stock



Modello Model	CC	Anni Years	Cilindro Cylinder (mm)	Versione Version	Pistone Completo / Complete Piston			Set Segmenti / Ring Set		Spinotto / Wrist Pin		Anellino / Circlip	
					Ø mm	Codice Code	€	Codice Code	€	Codice Code	€	Codice Code	€
HONDA													
MOTO 4 TEMPI - MOTORCYCLES 4 STROKE													
CRF450R compr. 12,0:1	450	2009-11	96,00	Pro Replica	95,95	23455A	160,66	590296000003	43,59	711144	8,04	72090	0,33
					95,96	23455B							
					95,97	23455C							
					95,98	23455D							
CRF450R compr. 12,9:1	450	2009-11	96,00	Pro-HC	95,95	23456A	172,68	590296000003	43,59	711144	8,04	72090	0,33
					95,96	23456B							
					95,97	23456C							
					95,98	23456D							
CRF450R CRE450X Big Bore	470	2003-08 2003-11	98,00	Pro-BB	97,96	22966200	172,68	590298000001	43,59	711144	8,04	72090	0,33
CRF450R CRE450X Big Bore compr.12,0:1	480	2003-08 2003-11	99,00	Pro-BB	98,96	23595A	172,68	590299000001	43,59	711144	8,04	72090	0,33
					98,97	23595B							
					98,98	23595C							
CRF450R Big Bore compr.12,0:1	480	2009-11	99,00	Pro-BB	98,96	23534A	172,68	590299000001	43,59	711144	8,04	72090	0,33
					98,97	23534B							
					98,98	23534C							
CRF450R CRE450X Big Bore compr.12,1:1	490	2003-08 2003-11	100,00	Pro-BB	99,96	22966A	172,68	590210000001	43,59	711144	8,04	72090	0,33
					99,97	22966B							
					99,98	22966C							
					99,99	22966D							
ATV 4 TEMPI - ATV 4 STROKE													
TRX350	350	1985-89	81,00	Replica	80,95	23164	101,07	590381000001	22,73	711164	8,04	72067	0,33
					+0,50	23164050		590381500001					
					+1,00	23164100		590382000001					
Sportmax 400EX TRX 400EX Compr. 10:1	400	1999-07	85,00	Replica	STD	23162	124,46	590385000001	27,03	711163	8,04	72075	0,33
					+0,50	23162050		590385500001					
					+1,00	23162100		590386000001					
Sportmax 400EX TRX 400EX Compr. 10:1	440	1999-07	87,00	Replica	+2,00	23234200	139,03	590387000001	29,25	711163	8,04	72075	0,33
					+3,00	23234300		590388000001					
					+4,00	23234400		590389000001					
TRX400EX Stroker NEW	460	1999-08	89,00	Replica	88,94	23610A	177,29	590389000002	29,25	715108	5,89	72025	0,33
TRX 450R	450	2004-05	94,00	Replica	93,97	23163A	141,79	590394000001	25,94	715375	8,04	72067	0,33
					93,98	23163B							
					93,99	23163C							
TRX 450R Compr. 11,5:1	450	2004-05	94,00	Pro-HC	93,95	23545A	172,68	590394000001	25,94	715406	11,91	72067	0,33
					93,96	23545B							
					93,97	23545C							
TRX 450R Compr. 13,1:1	450	2004-05	94,00	Pro-HC	93,95	23546A	172,68	590394000001	25,94	715406	11,91	72067	0,33
					93,96	23546B							
					93,97	23546C							
TRX 450R Big Bore	460	2004-05	96,00	Replica BB	95,95	23163200	172,68	590396000001	25,94	715375	8,04	72067	0,33
TRX 450R Big Bore Compr.10,5:1	479	2004-05	97,00	Replica BB	96,96	23531A	172,68	590397000002	43,59	715406	11,91	72067	0,33
					96,97	23531B							
					96,98	23531C							
TRX 450R Compr. 12,0:1	450	2006-09	96,00	Replica	95,95	23522A	160,26	590396000001	25,94	715398	10,35	72090	0,33
					95,96	23522B							
					95,97	23522C							
TRX 450R Compr. 13,5:1	450	2006-09	96,00	Pro-HC	95,95	23549A	172,68	590396000001	25,94	715398	10,35	72090	0,33
					95,96	23549B							
					95,97	23549C							
TRX 450R Big Bore Compr. 12,0:1	477	2006-09	99,00	Replica BB	98,95	23523A	181,65	590399000001	43,59	715398	10,35	72090	0,33
					98,96	23523B							
					96,97	23523C							

* Fino ad esaurimento scorte / Limited stock



Modello Model	CC	Anni Years	Cilindro Cylinder (mm)	Versione Version	Pistone Completo / Complete Piston			Set Segmenti / Ring Set		Spinotto / Wrist Pin		Anellino / Circlip	
					Ø mm	Codice Code	€	Codice Code	€	Codice Code	€	Codice Code	€
HONDA													
ATV 4 TEMPI - ATV 4 STROKE													
TRX700 NEW	700	2008-10	102,00	Replica	101,96	23638A	198,21	590310200002	49,11	711185	12,11	72103	0,33
					101,97	23638B							
					101,98	23638C							
TRX700 NEW	700	2008-10	102,00	Pro HC	101,96	23639A	215,80	590310200002	49,11	711185	12,11	72103	0,33
					101,97	23639B							
					101,98	23639C							
TRX700 NEW	727	2008-10	105,00	Replica BB	104,96	23640A	224,50	590310500001	50,63	711185	12,11	72103	0,33
					104,97	23640B							
					104,98	23640C							
HUSABERG													
MOTO 2 TEMPI - MOTORCYCLES 2 STROKE													
TE250 NEW	250	2011	66,40	Replica	66,34	23630A	123,38	55910006640	27,32	715372	4,51	72048	0,33
					66,35	23630B							
					66,36	23630C							
					66,37	23630D							
TE300 NEW	300	2011	72,00	Replica	71,94	23375A	143,45	53010007200	23,18	715372	4,51	72048	0,33
					71,95	23375B							
					71,96	23375C							
MOTO 4 TEMPI - MOTORCYCLES 4 STROKE													
FE450E	520	2009-10	102,00	PRO-BB	101,96	23368700	193,09	590210200001	49,17	715400	31,50	72090	0,33
HUSQVARNA													
MOTO 2 TEMPI - MOTORCYCLES 2 STROKE													
CR-WR-SM 125	125	1997-11	54,00	Replica	53,94	22600A	101,07	53010005400	16,01	711127	5,04	72071	0,33
					53,95	22600B							
					53,96	22600C							
					53,97	22600D							
					53,98	22600E							
CR-WR125	125	1988-91	56,00	Replica	55,96	21889A	77,35	53010005600	16,01	711121	4,90	72027	0,33
					55,97	21889B							
					55,98	21889C							
					55,99	21889D							
					56,00	21889E*							
CR-WR125	125	1992-94	56,00	Replica	55,95	22132AB	101,07	53010005600	16,01	711121	4,90	72027	0,33
					55,96	22132CD							
					55,97	22132EF							
CR-WR125	125	1995-96	56,00	Replica	55,95	22133AB	101,07	53010005600	16,01	711121	4,90	72027	0,33
					55,96	22133CD							
					55,97	22133EF							
WRE125 DP Dual	125	1994-96	56,00	Replica	55,95	22203AB	95,89	52712005600	12,69	715278	3,75	72027	0,33
					55,96	22203CD		52712005600					
					55,97	22203EF							
CR-WR250	250	1998-11	66,40	Replica	66,34	22601A	124,14	53010006640 53010006640	23,18 23,18	715372	4,51	72074	0,33
					66,35	22601B							
					66,36	22601C							
					66,37	22601D							
CR-WR250	250	1985-91	70,00	Replica	69,950	21757A*	113,11	53010007000	23,18	711125	4,90	72048	0,33
					69,95	21757AB							
					69,955	21757B*							
					69,960	21757C*							
					69,96	21757CD							
					69,965	21757D*							
					69,970	21757E*							
					69,97	21757EF							
69,975	21757F*												

* Fino ad esaurimento scorte / Limited stock



Modello Model	CC	Anni Years	Cilindro Cylinder (mm)	Versione Version	Pistone Completo / Complete Piston			Set Segmenti / Ring Set		Spinotto / Wrist Pin		Anellino / Circlip	
					Ø mm	Codice Code	€	Codice Code	€	Codice Code	€	Codice Code	€
HUSQVARNA													
MOTO 2 TEMPI - MOTORCYCLES 2 STROKE													
WR300	300	2008-11	72,00	Replica	71,94	23457A	143,45	53010007200	23,18	715372	4,51	72048	0,33
					71,95	23457B							
					71,96	23457C							
MOTO 4 TEMPI - MOTORCYCLES 4 STROKE													
TC-TE 250 Compr. 13.6:1	250	2009-11	79,00	Replica	78,95	23599A	159,53	59027900001	43,59	715421	10,87	72093	0,33
					78,96	23599B							
					78,97	23599C							
					78,98	23599D							
TC-TE 250 Compr. 14.0:1	250	2009-11	79,00	Pro-HC	78,95	23605A	171,23	59027900001	43,59	715421	10,87	72093	0,33
					78,96	23605B							
					78,97	23605C							
					78,98	23605D							
KAWASAKI													
MOTO 2 TEMPI - MOTORCYCLES 2 STROKE													
KXE50	50	1999-01	39,50	Replica	39,46	22525AB	40,61	53012503950	13,57	715036	2,25	72053	0,33
					39,47	22525CD							
					39,48	22525EF							
					39,49	22525GH							
KX65	65	2000-11	44,50	Replica	44,44	22860A	59,04	53010004450	13,80	715332	2,25	72065	0,33
					44,45	22860B							
					44,46	22860C							
					44,47	22860D							
KX65 Big Bore	75	2000-11	46,50	Big Bore	46,45	22882200	70,07	53010004650	13,80	715332	2,25	72065	0,33
KX80	80	1992-99	47,00	Replica	46,93	22445A	71,40	53009804700	14,46	715378	3,75	72050	0,33
					46,94	22445B							
					46,95	22445C							
					46,96	22445D							
KX80 USA	82	1992-00	48,00	Replica	47,93	22502A	71,40	53010004800	13,80	715378	3,75	72050	0,33
					47,94	22502B							
					47,95	22502C							
					47,96	22502D							
KX85	85	2001-11	48,50	Replica	48,44	22803A	71,40	53010004850	13,80	715378	3,75	72050	0,33
					48,45	22803B							
					48,46	22803C							
					48,47	22803D							
KX85 single ring	85	2001-11	48,50	Race	48,44	23637A	88,50	53010004850	13,80	715378	3,75	72050	0,33
					48,45	23637B							
					48,46	23637C							
					48,47	23637D							
KX85 Big Bore	100	2000-11	50,50	Big Bore	50,45	22875200	80,49	53010005050	13,80	715378	3,75	72050	0,33
KX100 NEW	100	1998-11	52,50	Replica	52,45	23614	114,15	53010005250	15,35	715286	5,04	72050	0,33
			53,00		52,95	23614050							
			54,50		54,45	23614200							
KX100 NEW single ring	100	1998-11	52,50	Race	52,45	23621	120,40	53010005250	15,35	715286	5,04	72050	0,33
			53,00		52,95	23621050							
			54,50		54,45	23621100							
KX-KXE125	125	1994	54,00	Replica	53,95	22245A	97,20	53010005400	16,01	711127	5,04	72071	0,33
					53,96	22245B							
					53,97	22245C							
					53,98	22245D							
KX-KXE125	125	1992-93	54,00	Replica	53,95	22248A	97,20	53010005400	16,01	715278	3,75	72055	0,33
					53,96	22248B							
					53,97	22248C							
					53,98	22248D							

* Fino ad esaurimento scorte / Limited stock



Modello Model	CC	Anni Years	Cilindro Cylinder (mm)	Versione Version	Pistone Completo / Complete Piston			Set Segmenti / Ring Set		Spinotto / Wrist Pin		Anellino / Circlip		
					Ø mm	Codice Code	€	Codice Code	€	Codice Code	€	Codice Code	€	
KAWASAKI														
MOTO 2 TEMPI - MOTORCYCLES 2 STROKE														
KX-KXE125	125	1995-97	54,00	Replica	53,95	22306A	97,20	53010005400	16,01	711127	5,04	72071	0,33	
					53,96	22306B								
					53,97	22306C								
					53,98	22306D								
KX-KXE125	125	1995-00	54,00	Race	53,95	22498A	107,27	53010005400	16,01	711127	5,04	72071	0,33	
					53,96	22498B								
					53,97	22498C								
					53,98	22498D								
KX-KXE125	125	1998	54,00	Replica	53,95	22509A	97,20	53010005400	16,01	711127	5,04	72071	0,33	
					53,96	22509B								
					53,97	22509C								
					53,98	22509D								
KX-KXE125	125	1998-00	54,00	Pro-Race	53,95	22550A	115,57	53010005400	16,01	711127	5,04	72071	0,33	
					53,96	22550B								
					53,97	22550C								
					53,98	22550D								
KX-KXE125	125	1999-00	54,00	Replica	53,95	22578A	97,20	53010005400	16,01	711127	5,04	72071	0,33	
					53,96	22578B								
					53,97	22578C								
					53,98	22578D								
KX-KXE125	125	2001-02	54,00	Replica	53,95	22712A	97,20	53010005400	16,01	711127	5,04	72071	0,33	
					53,96	22712B								
					53,97	22712C								
					53,98	22712D								
KX-KXE125	125	2003	54,00	Replica	53,95	22853A*	97,20	53010005400	16,01	711127	5,04	72071	0,33	
					53,96	22853B*								
					53,97	22853C*								
					53,98	22853D*								
KX-KXE125	125	2003-08	54,00	Replica	53,95	23004A	97,20	53010005400	16,01	711127	5,04	72071	0,33	
					53,96	23004B								
					53,97	23004C								
					53,98	23004D								
KX-KXE125	125	2001-08	54,00	Race	53,95	22714A	107,27	53010005400	16,01	711127	5,04	72071	0,33	
					53,96	22714B								
					53,97	22714C								
					53,98	22714D								
KX-KXE125	125	2001-08	54,00	Pro-Race	53,95	22716A	115,57	53010005400	16,01	711127	5,04	72071	0,33	
					53,96	22716B								
					53,97	22716C								
					53,98	22716D								
KX-KXE250	250	1992-97	66,40	Replica	66,35	22244A	119,42	53010006640	23,18	715372	4,51	72074	0,33	
					66,36	22244B		53010006640						23,18
					66,37	22244C								
					66,38	22244D								
KX-KXE250	250	1998-01	66,40	Replica	66,35	22521A	119,42	53010006640	23,18	715372	4,51	72074	0,33	
					66,36	22521B		53010006640						23,18
					66,37	22521C								
					66,38	22521D								
KX-KXE250	250	1998-01	66,40	Race	66,35	22579A	119,42	53010006640	23,18	715372	4,51	72074	0,33	
					66,36	22579B								
					66,37	22579C								
					66,38	22579D								
KX-KXE250	250	1998-01	66,40	Pro-Race	66,35	22644A	132,16	53010006640	23,18	715372	4,51	72074	0,33	
					66,36	22644B								
					66,37	22644C								
					66,38	22644D								

* Fino ad esaurimento scorte / Limited stock



Modello Model	CC	Anni Years	Cilindro Cylinder (mm)	Versione Version	Pistone Completo / Complete Piston			Set Segmenti / Ring Set		Spinotto / Wrist Pin		Anellino / Circlip			
					Ø mm	Codice Code	€	Codice Code	€	Codice Code	€	Codice Code	€		
KAWASAKI															
MOTO 2 TEMPI - MOTORCYCLES 2 STROKE															
KX-KXE250	250	2002-04	66,40	Replica	66,35	22795A	119,42	53010006640	23,18	53010006640	23,18	715372	4,51	72074	0,33
					66,36	22795B									
					66,37	22795C									
					66,38	22795D									
KX-KXE250	250	2002-04	66,40	Race	66,35	22797A	119,42	53010006640	23,18	53010006640	23,18	715372	4,51	72074	0,33
					66,36	22797B									
					66,37	22797C									
					66,38	22797D									
KX-KXE250	250	2002-04	66,40	Pro-Race	66,35	22799A	132,16	53010006640	23,18	53010006640	23,18	715372	4,51	72074	0,33
					66,36	22799B									
					66,37	22799C									
					66,38	22799D									
KX-KXE250	250	2005-08	66,40	Replica	66,35	23124A	119,42	53010006640	23,18	53010006640	23,18	715372	4,51	72074	0,33
					66,36	23124B									
					66,37	23124C									
					66,38	23124D									
KX-KXE250	250	2005-08	66,40	Race	66,35	23125A	119,42	53010006640	23,18	53010006640	23,18	715372	4,51	72074	0,33
					66,36	23125B									
					66,37	23125C									
					66,38	23125D									
KX-KXE250	250	2005-08	66,40	Pro-Race	66,35	23126A	132,16	53010006640	23,18	53010006640	23,18	715372	4,51	72074	0,33
					66,36	23126B									
					66,37	23126C									
					66,38	23126D									
MOTO 4 TEMPI - MOTORCYCLES 4 STROKE															
KX250F KXE250F compr. 12.6:1	250	2004-05	77,00	Pro Replica	76,95	22982A	149,18	590277000001	42,49	590277000001	42,49	715380	8,04	72055	0,33
					76,96	22982B									
					76,97	22982C									
					76,98	22982D									
KX250F KXE250F compr. 13.5:1 compr. 13.2:1	250	2006-08 2009	77,00	Pro Replica	76,95	23259A	149,18	590277000001	42,49	590277000001	42,49	715380	8,04	72055	0,33
					76,96	23259B									
					76,97	23259C									
					76,98	23259D									
KX250F KXE250F compr. 13.3:1	250	2004-06	77,00	Pro-HC	76,95	23114A	160,88	590277000001	42,49	590277000001	42,49	715380	8,04	72055	0,33
					76,96	23114B									
					76,97	23114C									
					76,98	23114D									
KX250F KXE250F compr. 13.9:1	250	2008-09	77,00	Pro-HC	76,95	23458A	160,88	590277000001	42,49	590277000001	42,49	715380	8,04	72055	0,33
					76,96	23458B									
					76,97	23458C									
					76,98	23458D									
KX250F KXE250F compr. 13.2:1	250	2010	77,00	Pro Replica	76,95	23566A	149,18	590277000001	42,49	590277000001	42,49	715380	8,04	72055	0,33
					76,96	23566B									
					76,97	23566C									
					76,98	23566D									
KX250F KXE250F compr. 13.8:1	250	2010	77,00	Pro-HC	76,95	23567A	160,88	590277000001	42,49	590277000001	42,49	715380	8,04	72055	0,33
					76,96	23567B									
					76,97	23567C									
					76,98	23567D									
KX250F NEW KXE250F compr. 13.2:1	250	2011	77,00	Pro Replica	76,95	23646A	149,18	590277000001	42,49	590277000001	42,49	715380	8,04	72055	0,33
					76,96	23646B									
					76,97	23646C									
					76,98	23646D									
KX250F NEW KXE250F compr. 13.9:1	250	2011	77,00	Pro-HC	76,95	23647A	160,88	590277000001	42,49	590277000001	42,49	715380	8,04	72055	0,33
					76,96	23647B									
					76,97	23647C									
					76,98	23647D									

* Fino ad esaurimento scorte / Limited stock



Modello Model	CC	Anni Years	Cilindro Cylinder (mm)	Versione Version	Pistone Completo / Complete Piston			Set Segmenti / Ring Set		Spinotto / Wrist Pin		Anellino / Circlip	
					Ø mm	Codice Code	€	Codice Code	€	Codice Code	€	Codice Code	€
KAWASAKI													
MOTO 4 TEMPI - MOTORCYCLES 4 STROKE													
KX250F KXE250F Big Bore	250	2004-09	79,00	Pro-BB	78,96	22982200	160,88	590279000001	43,59	715380	8,04	72055	0,33
KX250F Big Bore compr. 12,6:1	269	2004-09	80,00	Pro-BB	79,96	23405A	160,88	590280000001	43,59	715380	8,04	72055	0,33
					79,97	23405B							
					79,98	23405C							
KX250F KXE250F Big Bore	290	2004-09	83,00	Pro-BB	82,96	23245600	160,88	590283000002	43,59	715380	8,04	72055	0,33
KX250F KXE250F Big Bore	300	2004-09	84,00	Pro-BB	83,96	23231700	160,88	590284000002	43,59	715380	8,04	72055	0,33
KX250F NEW KXE250F	270	2010	80,00	Pro-BB	79,95	23680A	160,88	590280000001	43,59	715380	8,04	72055	0,33
					79,96	23680B							
					79,97	23680C							
KX250F NEW KXE250F	270	2011	80,00	Pro-BB	79,95	23654A	160,88	590280000001	43,59	715380	8,04	72055	0,33
					79,96	23654B							
					79,97	23654C							
KLX400	400	2003-06	90,00	Pro Replica	89,96	22951A	148,96	590390000001	40,83	711140	7,93	72075	0,33
					89,97	22951B							
					89,98	22951C							
KLX400 compr. 13,5:1	400	2000-09	90,00	Pro-HC	89,95	23550A	172,68	590390000001	40,83	711140	7,93	72075	0,33
					89,96	23550B							
					89,97	23550C							
KLX400 Big Bore	420	2003-06	91,00	Pro-BB	90,95	22973100	165,95	590391000001	40,83	711140	7,93	72075	0,33
KLX400 Big Bore	430	2003-06	92,00	Pro-BB	91,95	22973200	165,95	590392000001	40,83	711140	7,93	72075	0,33
KX450F KXE450F KLX450R compr. 12:1	450	2006-08 2008-10	96,00	Pro Replica	95,96	23242A	160,26	590296000001	43,59	711144	8,04	72090	0,33
					95,97	23242B							
					95,98	23242C							
					95,99	23242D							
KX450F KXE450F KLX450R compr. 13:1	450	2006-08 2008-10	96,00	Pro-HC	95,96	23243A	172,68	590296000001	43,59	711144	8,04	72090	0,33
					95,97	23243B							
					95,98	23243C							
					95,99	23243D							
KX450F compr. 12,7:1	450	2009-11	96,00	Pro Replica	95,96	23445A	160,26	590296000001	43,59	711144	8,04	72090	0,33
					95,97	23445B							
					95,98	23445C							
					95,99	23445D							
KX450F compr. 13,6:1	450	2009-11	96,00	Pro-HC	95,96	23446A	172,68	590296000001	43,59	711144	8,04	72090	0,33
					95,97	23446B							
					95,98	23446C							
					95,99	23446D							
ATV 4 TEMPI - ATV 4 STROKE													
KFX400	400	2003-06	90,00	Pro Replica	89,96	22951A	148,96	590390000001	40,83	711140	7,93	72075	0,33
					89,97	22951B							
					89,98	22951C							
KFX400 NEW Stroker	416	2003-06	90,00	Pro Replica	89,94	23609A	170,78	590390000001	40,83	711140	7,93	72075	0,33
KFX400 Big Bore	420	2003-06	91,00	Pro-BB	90,96	22973100	165,95	590391000001	40,83	711140	7,93	72075	0,33
KFX400 Big Bore	430	2003-06	92,00	Pro-BB	91,96	22973200	165,95	590392000001	40,83	711140	7,93	72075	0,33
KFX400 NEW Stroker	430	2003-06	92,00	Pro-BB	91,96	23635A	176,91	590392000002	43,59	711140	7,93	72075	0,33
KFX400 KLX400 Big Bore compr. 11,3:1	440	2003-06 2003-04	94,00	Pro BB	93,95	23533A	172,68	590394000001	25,94	711140	7,93	72075	0,33
					93,96	23533B							
					93,97	23533C							



Modello Model	CC	Anni Years	Cilindro Cylinder (mm)	Versione Version	Pistone Completo / Complete Piston			Set Segmenti / Ring Set		Spinotto / Wrist Pin		Anellino / Circlip	
					Ø mm	Codice Code	€	Codice Code	€	Codice Code	€	Codice Code	€
KAWASAKI													
ATV 4 TEMPI - ATV 4 STROKE													
KFX 450 Compr. 12,4:1	450	2008-11	96,00	Pro Replica	95,95	23543A	160,26	590396000001	25,94	715406	11,91	72067	0,33
					95,96	23543B							
					95,97	23543C							
KFX 450 Compr. 13,4:1	450	2008-11	96,00	Pro-HC	95,95	23544A	172,68	590396000001	25,94	715406	11,91	72067	0,33
					95,96	23544B							
					95,97	23544C							
KTM													
MOTO 2 TEMPI - MOTORCYCLES 2 STROKE													
EXC50	50	1994-97	39,50	Replica	39,46	22171A	40,61	53012503950 53012503950	13,57 13,57	715036	2,25	72065	0,33
					39,47	22171B							
					39,48	22171C							
					39,49	22171D							
					39,50	22171E							
					39,51	22171F							
EXC50	50	1994-97	39,50	Race	39,46	22367A*	40,61	53012503950	13,57	715036	2,25	72065	0,33
					39,47	22367B*							
					39,48	22367C*							
					39,49	22367D*							
EXC50	50	1998-00	39,50	Replica	39,46	22525AB	40,61	53012503950 53012503950	13,57 13,57	715036	2,25	72053	0,33
					39,47	22525CD							
					39,48	22525EF							
					39,49	22525GH							
SX50	50	2001-08	39,50	Replica	39,46	22813AB	40,61	53010003950	12,48	715036	2,25	72065	0,33
					39,47	22813CD							
					39,48	22813EF							
					39,49	22813GH							
SX50	50	2009-11	39,50	Replica	39,46	23429AB	40,61	53010003950	12,48	715036	2,25	72065	0,33
					39,47	23429CD							
					39,48	23429EF							
SX60	60	1997-08	43,50	Replica	43,46	22402A	43,86	53010004350	12,48	715332	2,25	72065	0,33
					43,47	22402B							
					43,48	22402C							
SX65	65	1997-08	45,00	Replica	44,96	22481AB	43,86	53010004500	13,80	715332	2,25	72065	0,33
					44,97	22481CD							
					44,98	22481EF							
SX65	65	2009-11	45,00	Replica	44,96	23430AB	43,86	53010004500	13,80	715332	2,25	72065	0,33
					44,97	23430CD							
					44,98	23430EF							
SX65 Big Bore	80	1997-08	47,00	Big Bore	46,95	22858200	61,25	53009804700	14,46	715047	2,25	72065	0,33
SX-EXC85	85	2003-11	47,00	Replica	46,94	23294A	71,41	53009804700	14,46	715378	3,75	72050	0,33
					46,95	23294B							
					46,96	23294C							
					46,97	23294D							
SX105	105	2004-11	52,00	Replica	51,95	22991A	88,27	53010005200	14,91	711151	4,61	72050	0,33
					51,96	22991B							
					51,97	22991C							
SX-EXC125	125	2001-11	54,00	Replica	53,94	23330A	101,87	55910005400 55910005400	19,83 19,83	711127	5,04	72071	0,33
					53,95	23330B							
					53,96	23330C							
					53,97	23330D							
SX-EXC125	125	2001-11	54,00	Race	53,94	23331A	101,87	55910005400	19,83	711127	5,04	72071	0,33
					53,95	23331B							
					53,96	23331C							
					53,97	23331D							

* Fino ad esaurimento scorte / Limited stock



Modello Model	CC	Anni Years	Cilindro Cylinder (mm)	Versione Version	Pistone Completo / Complete Piston			Set Segmenti / Ring Set		Spinotto / Wrist Pin		Anellino / Circlip	
					Ø mm	Codice Code	€	Codice Code	€	Codice Code	€	Codice Code	€
KTM													
MOTO 2 TEMPI - MOTORCYCLES 2 STROKE													
SX-GS125 dome t. bombata	125	1987-93	54,25	Replica	54,19	22293A	97,20	53010005425	16,01	711127	5,04	72071	0,33
					54,20	22293B							
					54,21	22293C							
					54,22	22293D							
					54,23	22293E							
SX-GS125 flat head t. piatta	125	1987-93	54,25	Replica	54,19	22295A*	97,20	53010005425	16,01	711127	5,04	72071	0,33
					54,20	22295B							
					54,21	22295C							
					54,22	22295D							
					54,23	22295E							
SX-EXC125	125	1994-97	54,25	Replica	54,19	22361A	107,27	53010005425	16,01	711127	5,04	72071	0,33
					54,20	22361B							
					54,21	22361C							
					54,22	22361D							
					54,23	22361E							
SX-EXC125	125	1998-00	54,25	Replica	54,19	22532A	97,20	53010005425	16,01	711127	5,04	72071	0,33
					54,20	22532B							
					54,21	22532C							
					54,22	22532D							
					54,23	22532E							
SX 144	144	2007-08	56,00	Replica	55,95	23383A	115,57	55910005600	19,83	715389	6,97	72071	0,33
					55,96	23383B							
SX 150	144	2009-11	56,00	Replica	55,95	23383A	115,57	55910005600	19,83	715389	6,97	72071	0,33
					55,96	23383B							
SX-EXC125	144	2007-11	58,00	Race-BB	57,95	23384	115,57	53010005800	17,10	715389	6,97	72071	0,33
SX-EXC200	200	1998-03	64,00	Replica	63,94	22907A*	119,42	53010006400	18,22	711147	5,89	72055	0,33
					63,95	22907B*							
					63,96	22907C*							
					63,97	22907D*							
SX200	200	1998-11	64,00	Replica	63,94	22925A	119,42	53010006400	18,22	711147	5,89	72055	0,33
					63,95	22925B							
					63,96	22925C							
					63,97	22925D							
EXC200	200	1998-11	64,00	Replica	63,94	22926A	126,90	53010006400	18,22	711147	5,89	72055	0,33
					63,95	22926B							
					63,96	22926C							
					63,97	22926D							
SX250	250	2000-02	66,40	Replica	66,34	22649A	119,42	53010006640	23,18	715372	4,51	72074	0,33
					66,35	22649B							
					66,36	22649C							
					66,37	22649D							
EXC250	250	2000-05	66,40	Replica	66,34	22650A	119,42	53010006640	23,18	715372	4,51	72074	0,33
					66,35	22650B							
					66,36	22650C							
					66,37	22650D							
SX250	250	2003-04	66,40	Replica	66,34	22909A	119,42	53010006640	23,18	715372	4,51	72048	0,33
					66,35	22909B							
					66,36	22909C							
					66,37	22909D							
SX250	250	2005	66,40	Replica	66,34	23121A*	119,42	53010006640	23,18	715372	4,51	72048	0,33
					66,35	23121B							
					66,36	23121C							
					66,37	23121D							

* Fino ad esaurimento scorte / Limited stock



Modello Model	CC	Anni Years	Cilindro Cylinder (mm)	Versione Version	Pistone Completo / Complete Piston			Set Segmenti / Ring Set		Spinotto / Wrist Pin		Anellino / Circlip	
					Ø mm	Codice Code	€	Codice Code	€	Codice Code	€	Codice Code	€
KTM													
MOTO 2 TEMPI - MOTORCYCLES 2 STROKE													
SX-EXC250	250	2006-11	66,40	Replica	66,34	23630A	123,38	55910006640	27,32	715372	4,51	72048	0,33
					66,35	23630B							
					66,36	23630C							
					66,37	23630D							
SX-EXC250	250	2006-10	66,40	Replica	66,34	23238A*	119,42	53010006640	23,18	715372	4,51	72048	0,33
					66,35	23238B*							
					66,36	23238C*							
					66,37	23238D*							
SX-GS250	250	1990-94	67,50	Replica	67,44	22442A	119,42	53010006750	23,18	711133	7,93	72060	0,33
					67,45	22442B							
					67,46	22442C							
					67,47	22442D							
SX-EXC250	250	1996-99	67,50	Replica	67,44	22459A	119,42	53010006750	23,18	711133	7,93	72060	0,33
					67,45	22459B							
					67,46	22459C							
					67,47	22459D							
EXC300	300	2004-07	72,00	Replica	71,94	22992A*	143,45	53010007200	23,18	715372	4,51	72048	0,33
					71,95	22992B*							
					71,96	22992C*							
EXC300	300	2004-11	72,00	Replica	71,94	23375A	143,45	53010007200	23,18	715372	4,51	72048	0,33
					71,95	23375B							
					71,96	23375C							
EXC360 EXC380	360	1996-01	78,00	Replica	77,94	22541A	154,09	53012507800	14,91	711132	7,93	72048	0,33
					77,95	22541B							
					77,96	22541C							
MOTO 4 TEMPI - MOTORCYCLES 4 STROKE													
EXC250F	250	2001-06	75,00	Pro Replica	74,95	22978A	152,26	590275000001	32,56	711140	7,93	72075	0,33
					74,96	22978B							
					74,97	22978C							
EXC250F Big Bore	280	2001-06	77,00	Pro-BB	76,96	22979200	171,26	590277000002	32,56	711140	7,93	72075	0,33
EXC250F	250	2001-06	75,00	Pro-HC	74,95	22980A	171,26	590275000001	32,56	711140	7,93	72075	0,33
					74,96	22980B							
					74,97	22980C							
SX250F EXC250F compr. 12.8:1	250	2006-11 2007-11	76,00	Pro Replica	75,96	23235A	152,26	590276000001	42,49	715402	26,39	72055	0,33
					75,97	23235B							
					75,98	23235C							
SX250F EXC250F compr. 13.3:1	250	2006-11 2007-11	76,00	Pro-HC	75,96	23236A	171,26	590276000001	42,49	715402	26,39	72055	0,33
					75,97	23236B							
					75,98	23236C							
SX250F Big Bore compr. 13.3:1	280	2006-11	80,00	Pro-BB	79,96	23274A	171,26	590280000002	50,20	715402	26,39	72055	0,33
					79,97	23274B							
					79,98	23274C							
SX250F Big Bore compr. 13.3:1	305	2006-11	84,00	Pro-BB	83,96	23296	171,26	590284000002	43,59	715402	26,39	72055	0,33
SX350F NEW compr. 13.5:1	350	2011	88,00	Pro Replica	87,96	23641A	184,86	590288000001	44,47	715431	33,95	72098	0,33
					87,97	23641B							
					87,98	23641C							
SX350F NEW compr. 14.0:1	350	2011	88,00	Pro-HC	87,96	23642A	198,05	590288000001	44,47	715431	33,95	72098	0,33
					87,97	23642B							
					87,98	23642C							



Modello Model	CC	Anni Years	Cilindro Cylinder (mm)	Versione Version	Pistone Completo / Complete Piston			Set Segmenti / Ring Set		Spinotto / Wrist Pin		Anellino / Circlip	
					Ø mm	Codice Code	€	Codice Code	€	Codice Code	€	Codice Code	€
KTM													
MOTO 4 TEMPI - MOTORCYCLES 4 STROKE													
SX350F NEW	366	2011	90,00	Pro-BB	89,96	23656A	198,05	590290000001	44,47	715431	33,95	72098	0,33
					89,97	23656B							
					89,98	23656C							
EXC450F compr. 11:1	450	2003-07	89,00	Pro Replica	88,94	23329A	166,58	590289000001	42,49	715108	5,69	72075	0,33
					88,95	23329B							
					88,96	23329C							
EXC450F compr.12:1	450	2003-07	89,00	Pro-HC	88,94	23340A	177,29	590289000001	42,49	715108	5,69	72075	0,33
					88,95	23340B							
					88,96	23340C							
SX450F compr. 12:1	450	2003-06	95,00	Pro Replica	94,93	22941A	167,72	590295000001	35,31	711140	7,93	72075	0,33
					94,94	22941B							
					94,95	22941C							
					94,96	22941D							
SX450F compr. 13:1	450	2003-06	95,00	Pro-HC	94,93	22968A	193,09	590295000001	35,31	711140	7,93	72075	0,33
					94,94	22968B							
					94,95	22968C							
					94,96	22968D							
SX450F Big Bore	470	2003-06	97,00	Pro-BB	96,96	22957200	193,09	590297000001	47,44	711140	7,93	72075	0,33
EXC450R compr.11.9:1	450	2008-11	95,00	Pro Replica	94,94	23379A	176,54	590295000002	32,01	715400	31,50	72090	0,33
					94,95	23379B							
					94,96	23379C							
EXC450R compr. 12.8:1	450	2008-11	95,00	Pro-HC	94,94	23380A	193,09	590295000002	32,01	715400	31,50	72090	0,33
					94,95	23380B							
					94,96	23380C							
EXC450R Big Bore compr. 11.9:1	520	2008-11	102,00	Pro-BB	101,95	23368700	193,09	590210200001	49,11	715400	31,50	72090	0,33
SX450F compr. 12.5:1	450	2007-11	97,00	Pro Replica	96,93	23342A	177,29	590297000002	49,11	715400	31,50	72090	0,33
					96,94	23342B							
					96,95	23342C							
					96,96	23342D							
SX450F compr. 13,2:1	450	2007-11	97,00	Pro-HC	96,93	23343A	193,09	590297000002	49,11	715400	31,50	72090	0,33
					96,94	23343B							
					96,95	23343C							
					96,96	23343D							
SX505F compr. 12.5:1	505	2008-09	100,00	Pro Replica	96,94	23417A	193,09	590210000001	43,59	711174	35,45	72073	0,33
					96,95	23417B							
					96,96	23417C							
SX-EXC520 SX-EXC525 compr. 11:1	510	2000-02 2003-07	95,00	Pro Replica	94,93	22942A	176,54	590295000001	35,31	711140	7,93	72075	0,33
					94,94	22942B							
					94,95	22942C							
					94,96	22942D							
SX-EXC520 SX-EXC525 compr. 12.5:1	510	2000-02 2003-07	95,00	Pro-HC	94,93	22969A	193,09	590295000001	35,31	711140	7,93	72075	0,33
					94,94	22969B							
					94,95	22969C							
					94,96	22969D							
SX-EXC520 SX-EXC525 Big Bore	530	2000-02 2003-07	97,00	Pro-BB	96,96	22958200	193,09	590297000002	45,84	711140	7,93	72075	0,33
EXC530R compr. 11.9:1	510	2008-11	95,00	Pro Replica	94,94	23381A	176,54	590295000002	32,01	715400	31,50	72090	0,33
					94,95	23381B							
					94,96	23381C							
EXC530R compr. 12.7:1	510	2008-11	95,00	Pro-HC	94,94	23382A	193,09	590295000002	32,01	715400	31,50	72090	0,33
					94,95	23382B							
					94,96	23382C							
EXC530R Big Bore	590	2008-11	102,00	Pro-BB	101,95	23369700	193,09	590210200001	47,44	715400	31,50	72090	0,33

* Fino ad esaurimento scorte / Limited stock



Modello Model	CC	Anni Years	Cilindro Cylinder (mm)	Versione Version	Pistone Completo / Complete Piston			Set Segmenti / Ring Set		Spinotto / Wrist Pin		Anellino / Circlip	
					Ø mm	Codice Code	€	Codice Code	€	Codice Code	€	Codice Code	€
KTM													
ATV 4 TEMPI - ATV 4 STROKE													
XC 450 compr. 11:1	450	2008-11	89,00	Pro Replica	88,94	23329A	177,29	590289000001	42,49	715108	5,69	72075	0,33
					88,95	23329B							
					88,96	23329C							
XC 450 compr. 12:1	450	2008-11	89,00	Pro-HC	88,94	23340A	176,54	590289000001	42,49	715108	5,69	72075	0,33
					88,95	23340B							
					88,96	23340C							
XC 450 compr. 13:1	450	2008-11	89,00	Pro-HC	88,94	23552A	176,54	590289000001	42,49	715409	7,93	72075	0,33
					88,95	23552B							
					88,96	23552C							
SX 450	450		97,00	Pro Replica	96,93	23342A	176,54	590297000002	49,11	715400	31,50	72090	0,33
					96,94	23342B							
					96,95	23342C							
					96,96	23342D							
SX450	450		97,00	Pro-HC	96,93	23343A	193,09	590297000002	49,11	715400	31,50	72090	0,33
					96,94	23343B							
					96,95	23343C							
					96,96	23343D							
SX-F 505 XC-F 505 compr. 12,5:1	505	2009-11	100,00	Pro Replica	99,94	23417A	193,09	590210000001	43,59	711174	35,45	72073	0,33
					99,95	23417B							
					99,96	23417C							
SX-F 505 XC-F 505 compr. 13,5:1	505	2009-11	100,00	Pro-HC	99,94	23417A	193,09	590210000001	43,59	711174	35,45	72073	0,33
					99,95	23417B							
					99,96	23417C							
XC 525 compr. 11:1	510	2008-11	95,00	Pro Replica	94,93	22942A	193,09	590295000001	35,31	711140	7,93	72075	0,33
					94,94	22942B							
					94,95	22942C							
					94,96	22942D							
XC 525 compr. 12,5:1	510	2008-11	95,00	Pro-HC	94,93	22969A	193,09	590295000001	35,31	711140	7,93	72075	0,33
					94,94	22969B							
					94,95	22969C							
					94,96	22969D							

KYMCO														
ATV 4 TEMPI - ATV 4 STROKE														
KXR-MXU	250		72,70	Race	72,66	23213	133,91	590372700001	49,82	715098	6,43	72092	0,33	
					+0,33	23213030								590373000001
					+0,55	23213055								590373250001
					+0,80	23213080								590373500001
					+1,30	23213130								590374000002

POLARIS														
ATV 2 TEMPI - ATV 2 STROKE														
Sportsman Scrambler 90	90	2001-05	52,00	Replica	51,95	23165	67,97	590252000001	22,63	715047	2,25	72065	0,33	
					+0,50	23165050								590252500001
					+1,00	23165100								590253000001
					+1,50	23165150								590253500001
Scrambler 250 Trial Boss 250 4x4 Trial Blazer 250	250		72,00	Replica	71,95	23166	101,51	590272000001	24,28	715376	4,51	72048	0,33	
					+0,50	23166050								590272500001
					+1,00	23166100								590273000001
					+1,50	23166150								590273500001
Trial Blazer 400	400	Thru 2003 fino al 2003	83,00	Replica	82,95	23215	109,80	590283000001	27,59	715376	4,51	72048	0,33	
					+0,50	23215050								590283500001
					+1,00	23215100								590284000001
					+1,50	23215150								590284500001
					+2,00	23215200	590285000001							

* Fino ad esaurimento scorte / Limited stock



Modello Model	CC	Anni Years	Cilindro Cylinder (mm)	Versione Version	Pistone Completo / Complete Piston			Set Segmenti / Ring Set		Spinotto / Wrist Pin		Anellino / Circlip	
					Ø mm	Codice Code	€	Codice Code	€	Codice Code	€	Codice Code	€
POLARIS													
ATV 4 TEMPI - ATV 4 STROKE													
Predator 500	500	2003-07	99,20	Replica	99,15	23167A	138,48	590399200001	27,59	711165	8,90	72095	0,33
Outlaw 500		2006-07			99,16	23167B							
					99,17	23167C							

SHERCO BULTACO													
MOTO 2 TEMPI - MOTORCYCLES 2 STROKE													
Trial 125	125		56,00	Replica	55,95	22623A	103,28	52712005600 52712005600	12,69 12,69	715242	2,69	72058	0,33
					55,96	22623B							
					55,97	22623C							
					55,98	22623D							
Trial 200	200		64,00	Replica	63,95	22624A	137,70	52712006400 52712006400	12,69 12,69	715258	2,58	72058	0,33
					63,96	22624B							
					63,97	22624C							
					63,98	22624D							
Trial 250	250		72,80	Replica	72,75	22674A	147,56	53010007280 53010007280	23,18 23,18	711125	4,90	72047	0,33
					72,76	22674B							
					72,77	22674C							
					72,78	22674D							
Trial 290	290		76,00	Replica	75,95	22625A	152,62	53515007600 53515007600	18,22 18,22	711125	4,90	72047	0,33
					75,96	22625B							
					75,97	22625C							
					75,98	22625D							

SUZUKI															
MOTO 2 TEMPI - MOTORCYCLES 2 STROKE															
RM65	65	2003-06	44,50	Replica	44,44	22860A	59,04	53010004450 53010004450	13,80 13,80	715332	2,25	72065	0,33		
					44,45	22860B									
					44,46	22860C									
					44,47	22860D									
RM65 Big Bore	75	1997-06	46,50	Big Bore	46,45	22882200	70,07	53010004650 53010004650	13,80 13,80	715332	2,25	72065	0,33		
RM80	80	1991-99	46,50	Replica	46,45	22444A	71,41	53010004650	13,80	715378	3,75	72050	0,33		
					46,46	22444B									
					46,47	22444C									
					46,48	22444D									
					46,49	22444E									
					46,50	22444F									
					46,95	22444G								53009804700	14,46
					47,45	22444H								53010004750	13,80
47,95	22444I	53010004800	13,80												
RM80 USA	80	1991-01	47,50	Replica	47,43	22501A	71,41	53010004750	13,80	715378	3,75	72050	0,33		
					47,44	22501B									
					47,45	22501C									
					47,94	22501D								53010004800	
					48,44	22501E								53010004850	
RM85	85	2002-11	48,00	Replica	47,94	22877A	71,41	53010004800	13,80	715378	3,75	72050	0,33		
					47,95	22877B									
					47,96	22877C									
					47,97	22877D									
RM85 Big Bore	100	2002-11	50,00	Big Bore	49,95	22880200	83,31	53010005000	15,53	715378	3,75	72050	0,33		
RM85 Supermini	110	2002-11	52,00	Big Bore	51,95	23205400	100,41	53010005200	14,91	711119	2,69	72050	0,33		
RM85 Supermini	110	2002-11	53,00	Big Bore	52,95	23205500	110,25	53010005300	15,35	711119	2,69	72050	0,33		

* Fino ad esaurimento scorte / Limited stock



Modello Model	CC	Anni Years	Cilindro Cylinder (mm)	Versione Version	Pistone Completo / Complete Piston			Set Segmenti / Ring Set		Spinotto / Wrist Pin		Anellino / Circlip	
					Ø mm	Codice Code	€	Codice Code	€	Codice Code	€	Codice Code	€
SUZUKI													
MOTO 2 TEMPI - MOTORCYCLES 2 STROKE													
RM125	125	1990-99	54,00	Replica	53,95	22216A	97,20	53010005400	16,01	711127	5,04	72071	0,33
					53,96	22216B							
					53,97	22216C							
					53,98	22216D							
RM125	125	1990-99	54,00	Race	53,95	22360A	107,27	53010005400	16,01	711127	5,04	72071	0,33
					53,96	22360B							
					53,97	22360C							
					53,98	22360D							
RM125 Flat head Testa Piatta	125	1990-99	54,00	Race	53,95	22382A*	107,27	53010005400	16,01	711127	5,04	72071	0,33
					53,96	22382B*							
					53,97	22382C*							
					53,98	22382D*							
RM125	125	1990-99	54,00	Pro-Race	53,95	22551A	115,57	53010005400	16,01	711127	5,04	72071	0,33
					53,96	22551B							
					53,97	22551C							
					53,98	22551D							
RM125	125	2000-03	54,00	Replica	53,95	22652A	97,20	53010005400	16,01	711127	5,04	72071	0,33
					53,96	22652B							
					53,97	22652C							
					53,98	22652D							
RM125	125	2000-03	54,00	Race	53,95	22642A*	107,27	53010005400	16,01	711127	5,04	72071	0,33
					53,96	22642B*							
					53,97	22642C*							
					53,98	22642D*							
RM125	125	2000-03	54,00	Pro-Race	53,95	22643A	115,57	53010005400	16,01	711127	5,04	72071	0,33
					53,96	22643B							
					53,97	22643C							
					53,98	22643D							
RM125	125	2004-11	54,00	Replica	53,95	22998A	97,20	53010005400	16,01	711127	5,04	72071	0,33
					53,96	22998B							
					53,97	22998C							
					53,98	22998D							
RM125	125	2004-11	54,00	Race	53,95	22999A	107,27	53010005400	16,01	711127	5,04	72071	0,33
					53,96	22999B							
					53,97	22999C							
					53,98	22999D							
RM125	125	2004-11	54,00	Pro-Race	53,95	23001A	115,57	53010005400	16,01	711127	5,04	72071	0,33
					53,96	23001B							
					53,97	23001C							
					53,98	23001D							
RM250	250	1996-97	66,40	Replica	66,34	22386A	119,42	53010006640	23,18	715372	4,51	72074	0,33
					66,35	22386B		53010006640					
					66,36	22386C							
					66,37	22386D							
RM250	250	1998	66,40	Replica	66,34	22540A	119,42	53010006640	23,18	715372	4,51	72074	0,33
					66,35	22540B		53010006640					
					66,36	22540C							
					66,37	22540D							
RM250	250	1999	66,40	Replica	66,34	22585A	119,42	53010006640	23,18	715372	4,51	72074	0,33
					66,35	22585B		53010006640					
					66,36	22585C							
					66,37	22585D							
RM250	250	1999	66,40	Race	66,34	22592A	119,42	53010006640	23,18	715372	4,51	72074	0,33
					66,35	22592B							
					66,36	22592C							
					66,37	22592D							

* Fino ad esaurimento scorte / Limited stock



Modello Model	CC	Anni Years	Cilindro Cylinder (mm)	Versione Version	Pistone Completo / Complete Piston			Set Segmenti / Ring Set		Spinotto / Wrist Pin		Anellino / Circlip	
					Ø mm	Codice Code	€	Codice Code	€	Codice Code	€	Codice Code	€
SUZUKI													
MOTO 2 TEMPI - MOTORCYCLES 2 STROKE													
RM250	250	2000-02	66,40	Replica	66,34	22646A	119,42	53010006640	23,18	715372	4,51	72074	0,33
					66,35	22646B							
					66,36	22646C							
					66,37	22646D							
RM250	250	2000-02	66,40	Race	66,34	22647A	119,42	53010006640	23,18	715372	4,51	72074	0,33
					66,35	22647B							
					66,36	22647C							
					66,37	22647D							
RM250	250	2000-02	66,40	Pro-Race	66,34	22648A*	132,16	53010006640	23,18	715372	4,51	72074	0,33
					66,35	22648B*							
					66,36	22648C*							
					66,37	22648D*							
RM250	250	2003-11	66,40	Replica	66,34	22854A	109,59	53010006640	23,18	715372	4,51	72074	0,33
					66,35	22854B							
					66,36	22854C							
					66,37	22854D							
RM250	250	2003-11	66,40	Race	66,34	22855A	109,59	53010006640	23,18	715372	4,51	72074	0,33
					66,35	22855B							
					66,36	22855C							
					66,37	22855D							
RM250	250	2003-11	66,40	Pro-Race	66,34	22856A	132,16	53010006640	23,18	715372	4,51	72074	0,33
					66,35	22856B							
					66,36	22856C							
					66,37	22856D							
RM250	250	1989-95	67,00	Replica	66,94	22215A	119,42	51312506700	23,18	715372	4,51	72074	0,33
					66,95	22215B							
					66,96	22215C							
					66,97	22215D							
MOTO 4 TEMPI - MOTORCYCLES 4 STROKE													
RMZ250 compr. 12.6:1	250	2004-06	77,00	Pro Replica	76,95	22982A	149,18	590277000001	42,49	715380	8,04	72055	0,33
					76,96	22982B							
					76,97	22982C							
					76,98	22982D							
RMZ250 compr. 13.4:1	250	2004-07	77,00	Pro-HC	76,95	23114A	160,88	590277000001	42,49	715380	8,04	72055	0,33
					76,96	23114B							
					76,97	23114C							
					76,98	23114D							
RMZ250 compr. 13.4:1	250	2007-09	77,00	Pro Replica	76,95	23311A	160,88	590277000001	42,49	715380	8,04	72055	0,33
					76,96	23311B							
					76,97	23311C							
					76,98	23311D							
RMZ250 compr. 13.9:1	250	2007-09	77,00	Pro-HC	76,95	23515A	160,88	590277000001	42,49	715380	8,04	72055	0,33
					76,96	23515B							
					76,97	23515C							
					76,98	23515D							
RMZ250 compr. 13.4:1	250	2010-11	77,00	Pro Replica	76,95	23564A	149,18	590277000001	42,49	715380	8,04	72055	0,33
					76,96	23564B							
					76,97	23564C							
					76,98	23564D							
RMZ250 compr. 13.8:1	250	2010-11	77,00	Pro-HC	76,95	23565A	160,88	590277000001	42,49	715380	8,04	72055	0,33
					76,96	23565B							
					76,97	23565C							
					76,98	23565D							

* Fino ad esaurimento scorte / Limited stock



Modello Model	CC	Anni Years	Cilindro Cylinder (mm)	Versione Version	Pistone Completo / Complete Piston			Set Segmenti / Ring Set		Spinotto / Wrist Pin		Anellino / Circlip	
					Ø mm	Codice Code	€	Codice Code	€	Codice Code	€	Codice Code	€
SUZUKI													
MOTO 4 TEMPI - MOTORCYCLES 4 STROKE													
RMZ250 Big Bore	250	2004-06	79,00	Pro-BB	78,96	22982200	160,88	590279000001	43,59	715380	8,04	72055	0,33
RMZ250 Big Bore compr. 12,6:1	269	2004-06	80,00	Pro-BB	79,96	23405A	160,88	590280000001	43,59	715380	8,04	72055	0,33
					79,97	23405B							
					79,98	23405C							
RMZ250 NEW Big Bore	270	2007-09	80,00	Pro-BB	79,96	23678A	160,88	590280000001	43,59	715380	8,04	72055	0,33
					79,97	23678B							
					79,98	23678C							
RMZ250 NEW Big Bore	270	2010-11	80,00	Pro-BB	79,96	23679A	160,88	590280000001	43,59	715380	8,04	72055	0,33
					79,97	23679B							
					79,98	23679C							
RMZ250 Big Bore	290	2004-06	83,00	Pro-BB	82,96	23245600	160,88	590283000002	43,59	715380	8,04	72055	0,33
RMZ250 Big Bore	300	2004-06	84,00	Pro-BB	83,96	23231700	160,88	590284000002	43,59	715380	8,04	72055	0,33
RMZ450 compr. 11.9:1	450	2005-07	95,50	Pro Replica	95,45	23198A	160,26	590295500001	43,59	715379	8,04	72090	0,33
					95,46	23198B							
					95,47	23198C							
					95,48	23198D							
RMZ450 compr. 13:1	450	2005-07	95,50	Pro-HC	95,45	23199A	172,68	590295500001	43,59	715379	8,04	72090	0,33
					95,46	23199B							
					95,47	23199C							
					95,48	23199D							
RMZ450 compr. 12.2:1	450	2008-11	96,00	Pro Replica	95,96	23377A	160,26	590296000001	43,59	715379	8,04	72090	0,33
					95,97	23377B							
					95,98	23377C							
RMZ450 compr. 12.9:1	450	2008-11	96,00	Pro-HC	95,96	23378A	172,68	590296000001	43,59	715379	8,04	72090	0,33
					95,97	23378B							
					95,98	23378C							
RMZ450 Big Bore compr. 12.8:1	500	2005-07	100,00	Pro-BB	99,95	23200450	172,68	590210000001	43,59	715379	8,04	72090	0,33
DRZ400	400	2000-09	90,00	Pro Replica	89,96	22951A	148,96	590390000001	40,83	711140	7,93	72075	0,33
					89,97	22951B							
					89,98	22951C							
DRZ400 compr. 13,5:1	400	2000-09	90,00	Pro-HC	89,95	23550A	172,68	590390000001	40,83	711140	7,93	72075	0,33
					89,96	23550B							
					89,97	23550C							
DRZ400 Big Bore	420	2000-09	91,00	Pro-BB	90,96	22973100	165,95	590391000001	40,83	711140	7,93	72075	0,33
DRZ400 Big Bore	428	2000-09	92,00	Pro-BB	91,96	22973200	165,95	590392000001	40,83	711140	7,93	72075	0,33
DRZ400 Big Bore Compr.11.3:1	440	2000-09	94,00	Pro-BB	93,95	23533A	172,68	590394000001	25,94	711140	7,93	72075	0,33
					93,96	23533B							
					93,97	23533C							
ATV 4 TEMPI - ATV 4 STROKE													
LTZ400 QuadSport	400	2000-09	90,00	Pro Replica	89,96	22951A	148,96	590390000001	40,83	711140	7,93	72075	0,33
					89,97	22951B							
					89,98	22951C							
LTZ400 NEW QuadSport Stroker	430	2000-09	90,00	Pro-BB	89,94	23609A	170,78	590390000001	40,83	711140	7,93	72075	0,33
LTZ400 Big Bore	420	2000-09	91,00	Pro-BB	90,96	22973100	172,68	590391000001	40,83	711140	7,93	72075	0,33
LTZ400 Big Bore	440	2000-09	92,00	Pro-BB	91,96	22973200	165,95	590392000001	40,83	711140	7,93	72075	0,33
LTZ400 NEW QuadSport Stroker	449	2000-09	92,00	Pro-BB	91,96	23635A	176,91	590392000002	43,59	711140	7,93	72075	0,33

* Fino ad esaurimento scorte / Limited stock



Modello Model	CC	Anni Years	Cilindro Cylinder (mm)	Versione Version	Pistone Completo / Complete Piston			Set Segmenti / Ring Set		Spinotto / Wrist Pin		Anellino / Circlip	
					Ø mm	Codice Code	€	Codice Code	€	Codice Code	€	Codice Code	€
SUZUKI													
ATV 4 TEMPI - ATV 4 STROKE													
LT-Z400 Big Bore Compr.11.3:1	440	2003-09	94,00	Pro-BB	93,95	23533A	172,68	590394000001	25,94	711140	7,93	72075	0,33
					93,96	23533B							
					93,97	23533C							
LT-R 450 Quadracer Compr.	450	2006-09 2008-11	95,50	Pro- Replica	95,45	23532A	160,66	590295500001	43,59	715379	8,04	72090	0,33
					95,46	23532B							
					95,47	23532C							
LT-R 450Quadracer Compr.13.0:1	450	2006-09 2008-11	95,50	Pro-HC	95,45	23553A	172,68	590295500001	43,59	715379	8,04	72090	0,33
					95,46	23553B							
					95,47	23553C							
LT-R 450 Quadracer Compr.11,7:1	474	2006-09 2008-11	98,00	Pro-BB	97,96	23521A	172,68	590398000001	43,59	711144	8,04	72090	0,33
					97,97	23521B							
					97,98	23521C							

TM RACING													
MOTO 2 TEMPI - MOTORCYCLES 2 STROKE													
TM85	85	2008-11	48,00	Replica	47,87	23666A	71,41	50420004800	16,05	715069	2,49	72066	0,33
					47,88	23666B							
					47,89	23666C							
					47,90	23666D							
TM125	125	1992-08	54,00	Replica	53,94	22389A	101,07	53010005400	16,01	711127	5,04	72049	0,33
					53,95	22389B							
					53,96	22389C							
					53,97	22389D							
					53,98	22389E							
TM250	250	1995-99	66,40	Replica	66,33	23249A	124,14	53010006640 53010006640	23,18 23,18	715372	4,51	72074	0,33
					66,34	23249B							
					66,35	23249C							
					66,36	23249D							
TM250	250	2000-08	66,40	Replica	66,33	22654A	124,14	53010006640	23,18	715372	4,51	72074	0,33
					66,34	22654B							
					66,35	22654C							
					66,36	22654D							
TM300	300		72,00	Replica	71,93	23703A	149,18	53010007200	23,18	715372	4,51	72048	0,33
					71,94	23703B							
					71,95	23703C							

VOR MOTORCYCLES													
MOTO 4 TEMPI - MOTORCYCLES 4 STROKE													
MX-EN-SM530	530	2002-05	97,00	Pro Replica	96,94	22994A	176,54	590297000001	49,11	711140	7,93	72075	0,33
					96,95	22994B							
					96,96	22994C							

YAMAHA													
MOTO 2 TEMPI - MOTORCYCLES 2 STROKE													
YZ80	80	1993-01	46,00	Replica	45,95	22443A	71,41	53010004600	13,80	715084	2,69	72050	0,33
					45,96	22443B							
					45,97	22443C							
					45,98	22443D							
YZ80 USA	82	1993-01	47,00	Replica	46,95	22500A	71,41	53009804700	14,46	715084	2,69	72050	0,33
					46,96	22500B							
					46,97	22500C							
					46,98	22500D							
YZ85	85	2002-11	47,50	Replica	47,44	22868A	71,41	53010004750	13,80	715378	3,75	72050	0,33
					47,45	22868B							
					47,46	22868C							
					47,47	22868D							
YZ85 Big Bore	100	2002-11	49,50	Big Bore	49,45	22871200	80,49	53010004950	14,35	715378	3,75	72050	0,33

* Fino ad esaurimento scorte / Limited stock



Modello Model	CC	Anni Years	Cilindro Cylinder (mm)	Versione Version	Pistone Completo / Complete Piston			Set Segmenti / Ring Set		Spinotto / Wrist Pin		Anellino / Circlip	
					Ø mm	Codice Code	€	Codice Code	€	Codice Code	€	Codice Code	€
YAMAHA													
MOTO 2 TEMPI - MOTORCYCLES 2 STROKE													
YZ85 NEW Supermini	104	2002-11	52,50	Pro-BB	52,44	23628A	121,31	53010005250	15,74	715286	5,04	72050	0,33
					52,45	23628B							
					52,46	23628C							
YZ-WR125	125	1994-96	54,00	Replica	53,93	22224A	97,20	53010005400	16,01	715061	2,69	72055	0,33
					53,94	22224B							
					53,95	22224C							
					53,96	22224D							
					53,97	22224E							
					53,93	22359A*							
YZ-WR125	125	1994-96	54,00	Race	53,94	22359B*	107,27	53010005400	16,01	715061	2,69	72055	0,33
					53,95	22359C*							
					53,96	22359D*							
					53,97	22359E*							
					53,93	22441A							
YZ-WR125	125	1997	54,00	Replica	53,94	22441B	97,20	53010005400	16,01	711127	5,04	72071	0,33
					53,95	22441C							
					53,96	22441D							
					53,97	22441E							
					53,93	22452A*							
YZ-WR125	125	1997	54,00	Race	53,94	22452B*	107,27	53010005400	16,01	711127	5,04	72071	0,33
					53,95	22452C*							
					53,96	22452D*							
					53,97	22452E*							
					53,93	22520A							
YZ-WR125	125	1998-01	54,00	Replica	53,94	22520B	97,20	53010005400	16,01	711127	5,04	72071	0,33
					53,95	22520C							
					53,96	22520D							
					53,97	22520E							
					53,93	22549A							
YZ-WR125	125	1998-01	54,00	Pro-Race	53,94	22549B	115,57	53010005400	16,01	711127	5,04	72071	0,33
					53,95	22549C							
					53,96	22549D							
					53,97	22549E*							
					53,93	22577A*							
YZ-WR125	125	1998-01	54,00	Race	53,94	22577B	107,27	53010005400	16,01	711127	5,04	72071	0,33
					53,95	22577C							
					53,96	22577D							
					53,97	22577E							
					53,93	22806A							
YZ-WR125	125	2002-04	54,00	Replica	53,94	22806B	97,20	53010005400	16,01	711127	5,04	72071	0,33
					53,95	22806C							
					53,96	22806D							
					53,97	22806E							
					53,93	22807A*							
YZ-WR125	125	2002-04	54,00	Race	53,94	22807B	107,27	53010005400	16,01	711127	5,04	72071	0,33
					53,95	22807C							
					53,96	22807D							
					53,97	22807E							
					53,93	22808A							
YZ-WR125	125	2002-04	54,00	Pro-Race	53,94	22808B	115,57	53010005400	16,01	711127	5,04	72071	0,33
					53,95	22808C							
					53,96	22808D							
					53,97	22808E							
					53,93	23119A							
YZ-WR125	125	2005-11	54,00	Replica	53,94	23119B	97,20	53010005400	16,01	711127	5,04	72071	0,33
					53,95	23119C							
					53,96	23119D							
					53,97	23119E							

* Fino ad esaurimento scorte / Limited stock



Modello Model	CC	Anni Years	Cilindro Cylinder (mm)	Versione Version	Pistone Completo / Complete Piston			Set Segmenti / Ring Set		Spinotto / Wrist Pin		Anellino / Circlip	
					Ø mm	Codice Code	€	Codice Code	€	Codice Code	€	Codice Code	€
YAMAHA													
MOTO 2 TEMPI - MOTORCYCLES 2 STROKE													
YZ-WR125	125	2005-11	54,00	Pro-Race	53,93	23120A	115,57	53010005400	16,01	711127	5,04	72071	0,33
					53,94	23120B							
					53,95	23120C							
					53,96	23120D							
					53,97	23120E							
YZ-WR125	125	1992-93	56,00	Replica	55,95	22152A	97,20	53010005600	16,01	715131	5,04	72055	0,33
					55,96	22152B							
					55,97	22152C							
					55,98	22152D							
YZ-WR144	144	2005-11	58,00	Pro-Race	57,95	23335A	115,57	53010005800	16,52	715389	6,97	72071	0,33
					57,96	23335B							
YZ-WR250	250	1999-11	66,40	Replica	66,34	22584A	107,59	53010006640 53010006640	23,18 23,18	715372	4,51	72074	0,33
					66,35	22584B							
					66,36	22584C							
					66,37	22584D							
YZ-WR250	250	1999-11	66,40	Race	66,34	22591A	107,59	53010006640	23,18	715372	4,51	72074	0,33
					66,35	22591B							
					66,36	22591C							
					66,37	22591D							
YZ-WR250	250	1999-11	66,40	Pro-Race	66,34	22645A	132,16	53010006640	23,18	715372	4,51	72074	0,33
					66,35	22645B							
					66,36	22645C							
					66,37	22645D							
YZ-WR250	250	1990-95	68,00	Replica	67,94	22154A	119,42	53012006800 53012006800	23,18 23,18	711117	5,04	72074	0,33
					67,95	22154B							
					67,96	22154C							
					67,97	22154D							
YZ-WR250	250	1990-95	68,00	Race	67,94	22226A*	119,42	53012006800	23,18	711117	5,04	72074	0,33
					67,95	22226B*							
					67,96	22226C*							
					67,97	22226D*							
YZ-WR250	250	1996-98	68,00	Replica	67,94	22356A	119,42	53012006800 53012006800	23,18 23,18	711117	5,04	72074	0,33
					67,95	22356B							
					67,96	22356C							
					67,97	22356D							
YZ-WR250	250	1998	68,00	Replica	67,94	22522A*	119,42	53012006800 53012006800	23,18 23,18	711117	5,04	72074	0,33
					67,95	22522B*							
					67,96	22522C*							
					67,97	22522D*							
MOTO 4 TEMPI - MOTORCYCLES 4 STROKE													
YZ250F WR250F compr. 12.7:1	250	2001-04	77,00	Pro Replica	76,94	22805A	149,18	590377000001	32,56	715381	8,04	72055	0,33
					76,95	22805B							
					76,96	22805C							
					76,97	22805D							
					76,98	22805E*							
YZ250F WR250F 2 rings- segmenti compr. 13.5:1	250	2001-07 2001-11	77,00	Pro-HC Race	76,94	22812A	160,88	590277000002	32,56	715381	8,04	72055	0,33
					76,95	22812B							
					76,96	22812C							
					76,97	22812D							
YZ250F WR250F 3 rings- segmenti compr. 13.5:1	250	2001-07 2001-11	77,00	Pro-HC	76,94	22889A	160,88	590377000001	32,56	715381	8,04	72055	0,33
					76,95	22889B							
					76,96	22889C							
					76,97	22889D							
					76,98	22889E*							

* Fino ad esaurimento scorte / Limited stock



Modello Model	CC	Anni Years	Cilindro Cylinder (mm)	Versione Version	Pistone Completo / Complete Piston			Set Segmenti / Ring Set		Spinotto / Wrist Pin		Anellino / Circlip	
					Ø mm	Codice Code	€	Codice Code	€	Codice Code	€	Codice Code	€
YAMAHA													
MOTO 4 TEMPI - MOTORCYCLES 4 STROKE													
YZ250F WR250F compr. 12.5:1	250	2005-07 2005-11	77,00	Pro Replica	76,94	23127A	149,18	590377000001	32,56	715381	8,04	72055	0,33
					76,95	23127B							
					76,96	23127C							
					76,97	23127D							
					76,98	23127E*							
YZ250F compr. 13.5:1	250	2008-11	77,00	Pro Replica	76,95	23391A	149,18	590377000001	32,56	715381	8,04	72055	0,33
					76,96	23391B							
					76,97	23391C							
					76,98	23391D							
YZ250F 2 rings- segmenti compr. 13.9:1	250	2008-11	77,00	Pro-HC Race	76,95	23394A	160,88	590277000002	32,56	715381	8,04	72055	0,33
					76,96	23394B							
					76,97	23394C							
					76,98	23394D							
YZ250F WR250F Big Bore	265	2001-04	79,00	Pro-BB	78,96	22954200	160,88	590379000001	43,59	715381	8,04	72055	0,33
YZ250F WR250F Big Bore	265	2005-07 2005-11	79,00	Pro-BB	78,96	23127200	160,88	590379000001	43,59	715381	8,04	72055	0,33
YZ250F WR250F Big Bore	270	2005-07 2005-11	80,00	Pro-BB	79,96	23129A	160,88	590280000001	43,59	715381	8,04	72055	0,33
					79,97	23129B							
					79,98	23129C							
YZ250F WR250F Big Bore	300	2005-11	84,00	Pro-BB	83,96	23233700	160,88	590284000002	43,59	715381	8,04	72055	0,33
YZ400F WR400F	400	1998-99 1998-02	92,00	Pro Replica	91,93	22567A	149,18	590392000002	43,59	715405	10,35	72074	0,33
					91,94	22567B							
					91,95	22567C							
					91,96	22567D							
YZ426F WR426F	426	2000-02 2001-02	95,00	Pro Replica	94,93	22605A	154,91	590395000002	33,66	711144	8,04	72090	0,33
					94,94	22605B							
					94,95	22605C							
					94,96	22605D							
					94,97	22605E							
YZ426F WR426F	426	2000-02 2001-02	95,00	Pro-Race	94,93	22651A	154,91	590295000002	32,01	711144	8,04	72090	0,33
					94,94	22651B							
					94,95	22651C							
					94,96	22651D							
					94,97	22651E							
YZ426F WR426F High Compression	426	2000-02 2001-02	95,00	Pro-HC	94,93	22891A	161,19	590395000001	32,01	711144	8,04	72090	0,33
					94,94	22891B							
					94,95	22891C							
					94,96	22891D							
					94,97	22891E							
YZ426F WR426F Big Bore	450	2000-02 2001-02	97,00	Pro-BB	96,96	22962200	166,84	590397000001	32,01	711144	8,04	72090	0,33
YZ450F WR450F compr. 12.5:1	450	2003-09 2003-11	95,00	Pro Replica	94,93	22915A	166,84	590395000001	32,01	715382	8,04	72074	0,33
					94,94	22915B							
					94,95	22915C							
					94,96	22915D							
YZ450F WR450F 2 rings- segmenti compr. 13.5:1	450	2003-09 2003-11	95,00	Pro-HC Race	94,93	22896A	172,68	590295000002	32,01	715382	8,04	72074	0,33
					94,94	22896B							
					94,95	22896C							
					94,96	22896D							
					96,96	22964A							
YZ450F Big Bore	480	2003-09	97,00	Pro-BB	96,97	22964B	172,68	590397000002	33,66	715382	8,04	72074	0,33
					96,98	22964C							



Modello Model	CC	Anni Years	Cilindro Cylinder (mm)	Versione Version	Pistone Completo / Complete Piston			Set Segmenti / Ring Set		Spinotto / Wrist Pin		Anellino / Circlip	
					Ø mm	Codice Code	€	Codice Code	€	Codice Code	€	Codice Code	€
YAMAHA													
MOTO 4 TEMPI - MOTORCYCLES 4 STROKE													
WR450F Big Bore	480	2005-11	97,00	Pro-BB	96,96	22964A	172,68	590397000002	33,66	715382	8,04	72074	0,33
					96,97	22964B							
					96,98	22964C							
YZ450F WR450F Big Bore compr.12,5:1	490	2003-09 2005-11	98,00	Pro-BB	97,96	23404A	172,68	590298000001	33,66	715382	8,04	72074	0,33
					97,97	23404B							
					97,98	23404C							
YZ450F WR450F Big Bore	500	2003-09 2005-11	100,00	Pro-BB	99,96	23270500	172,68	590210000001	43,59	715382	8,04	72074	0,33
YZ450F Compr. 12.5:1	450	2010-11	97,00	Pro Replica	96,93	23562A	166,84	590397000003	43,59	715405	10,35	72074	0,33
					96,94	23562B							
					96,95	23562C							
					96,96	23562D							
YZ450F Compr. 13.5:1	450	2010-11	97,00	Pro-HC	96,93	23563A	172,68	590297000004	43,59	715405	10,35	72074	0,33
					96,94	23563B							
					96,95	23563C							
					96,96	23563D							
YZ450F Big Bore	470	2010-11	99,00	Pro-BB	98,94	23655A	172,68	590299000001	43,59	715405	10,35	72074	0,33
					98,95	23655B							
					98,96	23655C							
ATV 2 TEMPI - ATV 2 STROKE													
YZF 350 Banshee 350 bicilindrico twin cylinder	350	Thru 2007 fino al 2007	64,00	Replica	63,95	22568	99,27	590264000001	27,04	715137	2,69	72055	0,33
					+0,25	22568025							
					+0,50	22568050							
					+0,75	22568075							
					+1,00	22568100							
					+1,50	22568150							
					+2,00	22568200							
YZF350 Banshee 350 Stroker	379 379 385 391 397 403	Thru 2007	64,00	Replica	63,95	23607	99,27	590264000001	27,04	715137	2,69	72055	0,33
			64,50		23607050								
			65,00		23607100								
			65,50		23607150								
			66,00		23607200								
			66,50		23607250								
			66,00		23607250								
YFS 200 Blaster 200	200	Thru 2006 fino al 2006	66,00	Replica	65,95	22569	80,60	590266000003	24,29	715137	2,69	72055	0,33
					+0,25	22569025							
					+0,50	22569050							
					+0,75	22569075							
					+1,00	22569100							
					+1,50	22569150							
					+2,00	22569200							
ATV 4 TEMPI - ATV 4 STROKE													
RAPTOR Compr. 10.75:1	250	2008-09	74,00	Pro-HC	73,95	23547A	129,90	590374000001	23,74	715407	10,35	72092	0,33
					73,96	23547B							
					73,97	23547C							
YFZ450S Quad compr. 12:1	450	2004-09	95,00	Pro Replica	94,95	22984A	160,43	590395000001	32,01	711140	7,93	72075	0,33
					94,96	22984B							
					94,97	22984C							
YFZ450S Quad compr. 13:1	450	2004-09	95,00	Pro-HC	94,95	23551A	172,68	590395000001	32,01	711140	7,93	72075	0,33
					94,96	23551B							
					94,97	23551C							
YZ450S QUAD Big Bore	470	2005-09	97,00	Pro Replica	96,95	23007A	172,57	590397000002	33,66	711140	7,93	72075	0,33
					96,96	23007B							
					96,97	23007C							
YFZ450S Quad Big Bore	480	2005-09	98,00	Pro-BB	97,95	23403A	178,50	590298000001	43,59	711140	7,93	72075	0,33
					97,96	23403B							
					97,97	23403C							



Modello Model	CC	Anni Years	Cilindro Cylinder (mm)	Versione Version	Pistone Completo / Complete Piston			Set Segmenti / Ring Set		Spinotto / Wrist Pin		Anellino / Circlip	
					Ø mm	Codice Code	€	Codice Code	€	Codice Code	€	Codice Code	€
YAMAHA													
ATV 4 TEMPI - ATV 4 STROKE													
YFM350 XT Warrior	350	1987-04	83,00	Replica	82,95	23103	101,51	590383000001	23,74	715107	5,69	72090	0,33
YFM350 WT Big Bear		Thru 1999			+0,50	23103050		590383500001					
Raptor350 compr. 10,25:1		2005-06			+1,00	23103100		590384000001					
Warrior- Raptor 350 Stroker	379	1987-09	84,00	Replica	83,94	23616A	170,78	590384000001	23,74	715107	5,69	72090	0,33
RAPTOR RHINO 660 Compr.11:1	660	2002-05	100,00	Pro-HC	99,95	23555A	168,50	590310000001	23,74	715270	11,91	72068	0,33
				99,96	23555B								
				99,97	23555C								
YFM660R Raptor	660	2001-05	100,00	Replica	99,95	23104	110,35	590310000001	24,83	715198	8,04	72068	0,33
YFM660F Grizzly		2002-08			+0,50	23104050		590310050001					
compr. 9,9:1		2005-07			+1,00	23104100		590310100001					
YFM660R- Raptor 660 Stroker	719	2001-05	102,00	Replica	101,95	23624A	187,86	590310200002	49,11	715270	11,91	72068	0,33
RAPTOR RHINO 700 Compr 9,2:1	700	2006-11	102,00	Replica	101,95	23623A	156,81	590310200002	49,11	715408	11,91	72100	0,33
				101,96	23623B								
				101,97	23623C								
RAPTOR RHINO 700 Compr.11: 1	700	2006-11	102,00	Pro-HC	101,95	23548A	172,50	590310200002	47,44	715408	11,91	72100	0,33
				101,96	23548B								
				101,97	23548C								
RAPTOR RHINO 700 Compr 9,2:1	730	2006-11	105,00	Pro-BB	104,95	23626A	189,41	590310500001	49,11	715408	11,91	72100	0,33
				104,96	23626B								
				104,97	23626C								



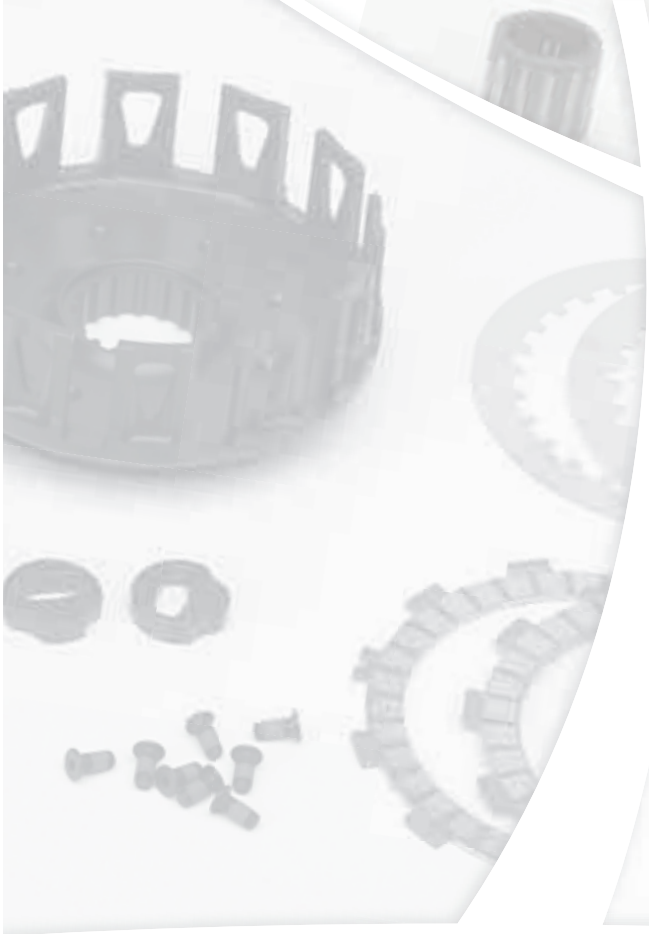



ON ROAD-SCOOTERS PISTONS
Pistoni strada - Scooters





Modello Model	CC	Anni Years	Cilindro Cylinder (mm)	Versione Version	Pistone Completo / Complete Piston			Set Segmenti / Ring Set		Spinotto / Wrist Pin		Anellino / Circlip	
					Ø mm	Codice Code	€	Codice Code	€	Codice Code	€	Codice Code	€
APRILIA													
2 TEMPI - 2 STROKE													
Amico, SR, Rally, Scarabeo, SRH20, Gulliver, Sonic, Area51	50		40,00	Replica	STD	22032	36,82	52715004000	2,54	715021	2,25	72024	0,33
					+0,25	22032025		52715004000	2,54				
					+0,50	22032050		52715004025	2,54				
					+0,75	22032075		52715004050	2,54				
					+1,00	22032100		52715004075	2,54				
					+1,25	22032125		52715004075	2,54				
					+1,50	22032150		52715004100	2,54				
					+2,00	22032200		52715004100	2,54				
AM 345	50		40,30	Replica	40,25	22088A	39,14	53015004030 52715004030	5,42	715038	2,25	72025	0,33
					40,26	22088B			5,42				
					40,27	22088C			2,54				
					40,28	22088D			5,42				
					40,29	22088E			2,54				
					40,31	22088F			5,42				
40,31	22088G	2,54											
SR50 DiTech	50	2000 30/6/03	41,00	Replica	STD	23202	39,14	53015004100	5,42	715040	2,25	72053	0,33
					+0,50	23202050		52715004100	2,54				
					+1,00	23202100		53015004150	5,42				
SR50 Pure Jet Injection	50	dal 01/07/03	40,00	Replica	STD	23372	25,07	53015004000	5,42	715036	2,25	72025	0,33
					+0,40	23372040		52715004000	2,54				
					+0,60	23372060		53015004040	5,42				
					+1,00	23372100		52715004040	2,54				
								53015004060	5,42				
Tuareg Nikasil Cylinder	125		54,00	Replica	53,93	21842A	88,14	53010005400	16,01	711127	5,04	72049	0,33
					53,94	21842B							
					53,95	21842C							
					53,96	21842D							
					53,97	21842E							
					53,98	21842F							
					53,99	21842G							
					54,00	21842H							
54,01	21842I												



Modello Model	CC	Anni Years	Cilindro Cylinder (mm)	Versione Version	Pistone Completo / Complete Piston			Set Segmenti / Ring Set		Spinotto / Wrist Pin		Anellino / Circlip	
					Ø mm	Codice Code	€	Codice Code	€	Codice Code	€	Codice Code	€
APRILIA													
2 TEMPI - 2 STROKE													
Tuareg Cast Iron Cylinder	125		54,00	Replica	STD	21938	90,60	53010005400	16,01	711127	5,04	72049	0,33
					+0,25	21938025		53010005400	16,01				
					+0,50	21938050		53010005425	16,01				
					+0,75	21938075		53010005425	16,01				
					+1,00	21938100		53010005450	16,01				
					+1,25	21938125		53010005450	16,01				
					+1,50	21938150		53010005475	16,01				
								53010005475	16,01				
Futura, AF1, RX, Red Rose, Rally, Syntesi, Pegaso, Tuareg Europe, Replica, RS125 Nikasil Cylinder	125		54,00	Replica	53,97	22003A	91,23	53010005400 53010005400	16,01 16,01	711127	5,04	72049	0,33
					53,98	22003B							
					53,99	22003C							
					54,00	22003D							
					54,01	22003E							
					54,02	22003F							
Extrema, Sport Production, RS125 Nikasil Cylinder	125		54,00	Race	53,93	22261A	91,53	53010005400	16,01	711127	5,04	72049	0,33
					53,94	22261B							
					53,95	22261C							
					53,96	22261D							
					53,97	22261E							
					53,98	22261F							
RS GP125 ring / segm. 1 mm	125		54,00	Race	53,965	22944A*	149,17	53010005400	16,01	711127	5,04	72071	0,33
					53,970	22944B*							
					53,975	22944C*							
					53,980	22944D*							
					53,985	22944E*							
					53,990	22944F*							
RS GP125 ring / segm. 0,8 mm	125		54,00	Race	53,965	23091A	160,66	53008005400	30,39	711127	5,04	72071	0,33
					53,970	23091B							
					53,975	23091C							
					53,980	23091D							
					53,985	23091E							
					53,990	23091F							
					53,995	23091G							
					54,000	23091H							
RS 250 Bicilindrico Twin	250		56,00	Replica	55,94	22796A	101,43	53010005600 53010005600	16,01 16,01	715061	2,69	72027	0,33
					55,95	22796B							
					55,96	22796C							
					55,97	22796D							
					55,98	22796E							

* Fino ad esaurimento scorte / Limited stock



Modello Model	CC	Anni Years	Cilindro Cylinder (mm)	Versione Version	Pistone Completo / Complete Piston			Set Segmenti / Ring Set		Spinotto / Wrist Pin		Anellino / Circlip	
					Ø mm	Codice Code	€	Codice Code	€	Codice Code	€	Codice Code	€
APRILIA													
2 TEMPI - 2 STROKE													
RS 250 Bicilindrico Twin 1 ring/segm.	250		56,00	Race	55,94	22800A	101,43	53010005600	16,01	715061	2,69	72027	0,33
					55,95	22800B							
					55,96	22800C							
					55,97	22800D							
4 TEMPI - 4 STROKE													
Atlantic, Scarabeo	250	2004-05	72,00	Race	71,96	23214	84,96	590372000001	49,50	715383	5,69	72049	0,33
					+0,25	23214025		590372250001					
					+0,50	23214050		590372500001					
					+0,75	23214075		590372750001					
Leonardo	300		71,00	Race	70,97	23208200	138,73	590371000001	48,74	711159	5,69	72092	0,33

BENELLI													
2 TEMPI - 2 STROKE													
Scooter 491, K2, Pepe	50		40,00	Replica	STD	22032	36,82	52715004000	2,54	715021	2,25	72024	0,33
					+0,25	22032025		52715004000	2,54				
					+0,50	22032050		52715004025	2,54				
					+0,75	22032075		52715004050	2,54				
					+1,00	22032100		52715004075	2,54				
					+1,25	22032125		52715004075	2,54				
					+1,50	22032150		52715004100	2,54				
					+2,00	22032200		52715004100	2,54				
								52715004125	2,54				
								52715004125	2,54				

BETAMOTOR													
2 TEMPI - 2 STROKE													
Supermotard 50	50		39,50	Replica	39,46	22525AB	40,61	53012503950	13,57	715363	2,25	72053	0,33
					39,47	22525CD		53012503950	13,57				
					39,48	22525EF							
					39,49	22525GH							
Scooter Tempo, Quadra, Nemo, Ark, Chrono, 502, Eikon	50		40,00	Replica	STD	22032	36,82	52715004000	2,54	715021	2,25	72024	0,33
					+0,25	22032025		52715004000	2,54				
					+0,50	22032050		52715004025	2,54				
					+0,75	22032075		52715004025	2,54				
					+1,00	22032100		52715004050	2,54				
					+1,25	22032125		52715004050	2,54				
					+1,50	22032150		52715004075	2,54				
					+2,00	22032200		52715004075	2,54				
								52715004100	2,54				
								52715004100	2,54				



Modello Model	CC	Anni Years	Cilindro Cylinder (mm)	Versione Version	Pistone Completo / Complete Piston			Set Segmenti / Ring Set		Spinotto / Wrist Pin		Anellino / Circlip	
					Ø mm	Codice Code	€	Codice Code	€	Codice Code	€	Codice Code	€
CAGIVA													
2 TEMPI - 2 STROKE													
Mito	125	1990-07	56,00	Replica	55,96	22087A	74,90	52712005600	12,69	715130	2,69	72027	0,33
					55,97	22087B							
					55,98	22087C							
					55,99	22087D							
					56,00	22087E							
					56,01	22087F							
Mito testa piatta flat head	125	1990-07	56,00	Race	55,95	22117AB	122,64	53010005600	12,69	711121	4,73	72027	0,33
					55,96	22117CD							
					55,97	22117EF							

DR - Diffusione Ricambi													
2 TEMPI - 2 STROKE													
Minarelli Yamaha Perform. Kit	70		46,00	Replica	STD	22372	38,84	52915004600	11,37	715025	2,25	72024	0,33
					+0,40	22372040		52915004600	11,37				
					+0,80	22372080		52915004640	11,37				
					+1,00	22372100		52915004640	11,37				
					+1,40	22372140		52915004680	11,37				
					+1,80	22372180		52915004680	11,37				
					+2,00	22372200		52915004700	11,37				
								52915004700	11,37				
								52915004740	11,37				
								52915004740	11,37				
Piaggio Vespa 3 ports 3 travasi	75		47,00	Replica	STD	21588*	31,42	52615004700	3,09	715047	2,25	72025	0,33
					+0,40	21588040*		52615004700	3,09				
					+0,80	21588080*		52615004740	3,09				
					+1,00	21588100*		52615004740	3,09				
					+1,40	21588140*		52615004780	3,09				
					+1,60	21588160*		52615004780	3,09				
					+2,00	21588200*		52615004800	3,09				
								52615004800	3,09				
								52615004840	3,09				
								52615004840	3,09				
Piaggio Vespa 6 ports 6 travasi	75		47,00	Replica	STD	21745*	31,42	52615004700	3,09	715047	2,25	72025	0,33
					+0,40	21745040*		52615004700	3,09				
					+0,80	21745080*		52615004740	3,09				
					+1,00	21745100*		52615004740	3,09				
					+1,40	21745140*		52615004780	3,09				
					+1,60	21745160*		52615004780	3,09				
					+2,00	21745200*		52615004800	3,09				
								52615004800	3,09				
								52615004840	3,09				
								52615004840	3,09				

* Fino ad esaurimento scorte / Limited stock



Modello Model	CC	Anni Years	Cilindro Cylinder (mm)	Versione Version	Pistone Completo / Complete Piston			Set Segmenti / Ring Set		Spinotto / Wrist Pin		Anellino / Circlip	
					Ø mm	Codice Code	€	Codice Code	€	Codice Code	€	Codice Code	€
DR - Diffusione Ricambi													
2 TEMPI - 2 STROKE													
Honda Peugeot Perform. Kit	75		47,00	Replica	STD	22374	32,66	52615004700	3,09	715042	2,25	72025	0,33
					+0,40	22374040		52615004700	3,09				
					+0,80	22374080		52615004740	3,09				
					+1,00	22374100		52615004780	3,09				
								52615004800	3,09				
Sfera Typhoon Perform. Kit	75		48,00	Replica	STD	22362	35,14	52915004800	11,37	715336	2,25	72025	0,33
					+0,40	22362040		52915004800	11,37				
					+0,80	22362080		52915004840	11,37				
					+1,00	22362100		52915004840	11,37				
								52915004880	11,37				

DERBI													
2 TEMPI - 2 STROKE													
Vamos Fura Hunter Aventura Predator Manhattan	50		41,00	Replica	STD	22138	40,97	53015004100	5,42	715353	2,25	72024	0,33
					+0,25	22138025		53015004100	5,42				
					+0,50	22138050		53015004125	5,42				
					+0,75	22138075		53015004125	5,42				
					+1,00	22138100		53015004150	5,42				
					+1,25	22138125		53015004150	5,42				
					+1,50	22138150		53015004175	5,42				
								53015004175	5,42				
Senda	50		39,88	Replica	39,84	23359A	40,97	53010003990	8,28	715035	2,25	72025	0,33
					39,85	23359B		53010003990	8,28				
					39,86	23359C		53010003990	8,28				
					39,87	23359D		53010003990	8,28				
								53010003990	8,28				
Senda	50		39,88	Race	39,82	22775A	40,97	53010003990	8,28	715035	2,25	72025	0,33
					39,83	22775B							
					39,84	22775C							
4 TEMPI - 4 STROKE													
Senda	125		54,00	Replica	53,97	23349	108,16	590354000001	38,03	715262	2,69	72049	0,33
					+0,25	23349025		590354250001					
					+0,50	23349050		590354500001					
					+2,00	23349200		590356000001					



Modello Model	CC	Anni Years	Cilindro Cylinder (mm)	Versione Version	Pistone Completo / Complete Piston			Set Segmenti / Ring Set		Spinotto / Wrist Pin		Anellino / Circlip			
					Ø mm	Codice Code	€	Codice Code	€	Codice Code	€	Codice Code	€		
GILERA															
2 TEMPI - 2 STROKE															
Bullit	50		39,00	Replica	38,97	22033AB	37,91	52710003900	5,42	715240	2,25	72025	0,33		
					38,98	22033CD								52710003900	5,42
					38,99	22033EF									
Typhoon Storm Runner Stalker Easy Moving	50		40,00	Replica	STD	22061	25,07	52715004000	2,54	715036	2,25	72025	0,33		
					+0,20	22061020		52715004020	2,54						
					+0,40	22061040		52715004040	2,54						
					+0,60	22061060		52715004060	2,54						
					+0,80	22061080		52715004080	2,54						
					+1,00	22061100		52715004100	2,54						
					+1,40	22061140		52715004140	2,54						
					+1,60	22061160		52715004160	2,54						
					+2,00	22061200		52715004200	2,54						
SP01 SP02	125		56,00	Replica	55,965	22013AB	89,99	53010005600	16,01	715242	2,69	72058	0,33		
					55,975	22013CD								53010005600	16,01
					55,985	22013EF									
					55,995	22013GH									
SP01 SP02	125		56,00	Race	55,965	22341AB	77,04	53010005600	16,01	715242	2,69	72058	0,33		
					55,975	22341CD									
					55,985	22341EF									
					55,995	22341GH									

HONDA													
2 TEMPI - 2 STROKE													
NSR	50		39,00	Replica	STD	22030	40,68	53012003900	9,27	715035	2,25	72025	0,33
					+0,25	22030025		53012003925	9,27				
					+0,50	22030050		53012003950	9,27				
					+0,75	22030075		53012003975	9,27				
					+1,00	22030100		53012004000	9,27				

* Fino ad esaurimento scorte / Limited stock



Modello Model	CC	Anni Years	Cilindro Cylinder (mm)	Versione Version	Pistone Completo / Complete Piston			Set Segmenti / Ring Set		Spinotto / Wrist Pin		Anellino / Circlip	
					Ø mm	Codice Code	€	Codice Code	€	Codice Code	€	Codice Code	€
HONDA													
2 TEMPI - 2 STROKE													
SC01 GP Dio ZX Bali SFX Sky Shadow SXR X8R	50		39,00	Replica	STD	22383	40,68	53015003900	5,42	715240	2,25	72025	0,33
					+0,25	22383025		53015003925	5,42				
					+0,50	22383050		53015003925	5,42				
					+0,75	22383075		53015003950	5,42				
								53015003950	5,42				
					+1,00	22383100		53015003975	5,42				
		53015003975	5,42										
							53015004000	5,42					
							53015004000	5,42					
SH	50		40,00	Replica	STD	22023*	39,14	53015004000	5,42	715021	2,25	72003	0,33
					+0,25	22023025*		52715004000	2,54				
					+0,50	22023050*		53015004025	5,42				
								52715004025	2,54				
					+0,75	22023075*		53015004050	5,42				
								52715004050	2,54				
					+1,00	22023100*		53015004075	5,42				
								52715004075	2,54				
+1,25	22023125*	53015004100	5,42										
		52715004100	2,54										
+1,40	22023140*	53015004125	5,42										
		52715004125	2,54										
+1,50	22023150*	53015004140	5,42										
		52715004140	2,54										
							53015004150	5,42					
							52715004150	2,54					
PXR	50		40,00	Replica	STD	22082*	36,08	53015004000	5,42	715021	2,25	72003	0,33
					+0,25	22082025*		52715004000	2,54				
					+0,50	22082050*		53015004025	5,42				
								52715004025	2,54				
					+0,75	22082075*		53015004050	5,42				
		52715004050	2,54										
+1,00	22082100*	53015004075	5,42										
		52715004075	2,54										
							53015004100	5,42					
							52715004100	2,54					
Vision Vision 2	50		41,00	Replica	STD	22024	37,34	53015004100	5,42	715021	2,25	72003	0,33
					+0,25	22024025		52715004100	2,54				
					+0,50	22024050		53015004125	5,42				
								52715004125	2,54				
					+0,75	22024075		53015004150	5,42				
								52715004150	2,54				
					+1,00	22024100		53015004175	5,42				
		52715004175	2,54										
+1,25	22024125	53015004200	5,42										
		52715004200	2,54										
+1,50	22024150	53015004225	5,42										
		52715004225	2,54										
							53015004250	5,42					
							52715004250	2,54					
NSR KY4 CRM	125		54,00	Replica	53,96	21972A	85,36	55910005400	19,83	715061	2,69	72055	0,33
					53,97	21972B							
					53,98	21972C							
					53,99	21972D							
					54,00	21972E							
					54,01	21972F							

* Fino ad esaurimento scorte / Limited stock



Modello Model	CC	Anni Years	Cilindro Cylinder (mm)	Versione Version	Pistone Completo / Complete Piston			Set Segmenti / Ring Set		Spinotto / Wrist Pin		Anellino / Circlip	
					Ø mm	Codice Code	€	Codice Code	€	Codice Code	€	Codice Code	€
HONDA													
2 TEMPI - 2 STROKE													
RS GP	125	1992-94	54,00	Race	53,93	22175A	134,67	53010005400	16,01	711151	4,61	72050	0,33
					53,94	22175B							
					53,95	22175C							
					53,96	22175D							
					53,97	22175E							
					53,98	22175F							
RS GP	125	1995-97	54,00	Race	53,93	22429A*	134,67	53010005400	16,01	711127	5,04	72049	0,33
					53,94	22429B*							
					53,95	22429C*							
					53,96	22429D*							
					53,97	22429E*							
					53,98	22429F*							
RS GP Testa Bomb. Dome head	125	2003-09	54,00	Race	53,94	23105A	165,51	53007805400	32,52	711127	5,04	72071	0,33
					53,95	23105B							
					53,96	23105C							
RS GP Testa Piatta Flat head	125	2003-09	54,00	Race	53,94	23224A	165,51	53007805400	32,52	711127	5,04	72071	0,33
					53,95	23224B							
					53,96	23224C							
					53,97	23224D							
NS MTX	125		56,00	Replica	55,96	21725A	85,05	53010005600 53010005600	16,01 16,01	715061	2,69	72055	0,33
					55,97	21725B							
					55,98	21725C							
					55,99	21725D							
					56,00	21725E							
4 TEMPI - 4 STROKE													
SH Dylan Pantheon @	150		58,00	Replica	57,97	23220	99,10	590358000001 590358250001 590358500001	42,32 42,32 42,32	715084	2,69	72093	0,33
					+0,25	23220025							
					+0,50	23220050							
ITALJET													
2 TEMPI - 2 STROKE													
Dragster Pista Bazooka Yankee Ascott Reporter	50		40,00	Replica	STD	22032	36,82	52715004000 52715004000 52715004025 52715004025 52715004050 52715004050 52715004075 52715004075 52715004100 52715004100 52715004125 52715004125 52715004150 52715004150 52715004200 52715004200	2,54 2,54 2,54 2,54 2,54 2,54 2,54 2,54 2,54 2,54 2,54 2,54 2,54 2,54 2,54	715021	2,25	72024	0,33
					+0,25	22032025							
					+0,50	22032050							
					+0,75	22032075							
					+1,00	22032100							
					+1,25	22032125							
					+1,50	22032150							
					+2,00	22032200							

* Fino ad esaurimento scorte / Limited stock



Modello Model	CC	Anni Years	Cilindro Cylinder (mm)	Versione Version	Pistone Completo / Complete Piston			Set Segmenti / Ring Set		Spinotto / Wrist Pin		Anellino / Circlip	
					Ø mm	Codice Code	€	Codice Code	€	Codice Code	€	Codice Code	€
ITALJET													
2 TEMPI - 2 STROKE													
Formula Cruise Torpedo Velocifero	50		41,00	Replica	STD	22138	40,97	53015004100	11,37	715353	2,25	72024	0,33
					+0,25	22138025		53015004100	11,37				
					+0,50	22138050		53015004125	11,37				
					+0,75	22138075		53015004125	11,37				
					+1,00	22138100		53015004150	11,37				
					+1,25	22138125		53015004150	11,37				
					+1,50	22138150		53015004175	11,37				
								53015004175	11,37				
		53015004200	11,37										
		53015004200	11,37										
		53015004225	11,37										
		53015004225	11,37										
		53015004250	11,37										
		53015004250	11,37										

KYMCO													
2 TEMPI - 2 STROKE													
Sniper DD Heroism Calypso Spacer	50		39,00	Replica	STD	22221*	40,68	53015003900	5,42	715240	2,25	72025	0,33
					+0,25	22221025*		53015003900	5,42				
					+0,50	22221050*		53015003925	5,42				
					+0,75	22221075*		53015003925	5,42				
					+1,00	22221100*		53015003950	5,42				
DJ, CX, KB, K12 Scout Looping Top Boy Cobra People Dink	50		39,00	Replica	STD	22383	40,68	53015003975	5,42	715240	2,25	72025	0,33
					+0,25	22383025		53015003975	5,42				
					+0,50	22383050		53015003975	5,42				
					+0,75	22383075		53015003975	5,42				
					+1,00	22383100		53015004000	5,42				
		53015004000	5,42										
4 TEMPI - 4 STROKE													
Dink Gran Dink B&W	125		52,40	Race	52,36	23211	102,30	590352400001	42,32	715241	2,69	72049	0,33
					+0,35	23211035		590352750001					
					+0,60	23211060		590353000001					
Dink Gran Dink B&W	150		57,40	Race	57,36	23212	102,30	590357400001	42,32	715262	2,69	72049	0,33
					+0,40	23212040		590357800001					
					+0,80	23212080		590358200001					
					+1,00	23212100		590358400001					
Gran Dink B&W, Yup People	250		72,70	Race	72,66	23213	133,91	590372700001	48,13	715098	6,21	72092	0,33
					+0,33	23213030		590373000001					
					+0,55	23213055		590373250001					
					+0,80	23213080		590373500001					
					+1,30	23213130		590374000002					

* Fino ad esaurimento scorte / Limited stock



Modello Model	CC	Anni Years	Cilindro Cylinder (mm)	Versione Version	Pistone Completo / Complete Piston			Set Segmenti / Ring Set		Spinotto / Wrist Pin		Anellino / Circlip			
					Ø mm	Codice Code	€	Codice Code	€	Codice Code	€	Codice Code	€		
MALAGUTI															
2 TEMPI - 2 STROKE															
F10 F12 F15 Centro Yesterday	50		40,00	Replica	STD	22032	36,82	52715004000	2,54	715021	2,25	72024	0,33	52715004000	2,54
					+0,25	22032025		52715004025	2,54					52715004025	2,54
					+0,50	22032050		52715004050	2,54					52715004050	2,54
					+0,75	22032075		52715004075	2,54					52715004075	2,54
					+1,00	22032100		52715004100	2,54					52715004100	2,54
					+1,25	22032125		52715004125	2,54					52715004125	2,54
					+1,50	22032150		52715004150	2,54					52715004150	2,54
					+2,00	22032200		52715004200	2,54					52715004200	2,54
Crosser	50		41,00	Replica	STD	22138	40,97	53015004100	5,42	715353	2,25	72024	0,33	53015004100	5,42
					+0,25	22138025		53015004125	5,42					53015004125	5,42
					+0,50	22138050		53015004150	5,42					53015004150	5,42
					+0,75	22138075		53015004175	5,42					53015004175	5,42
					+1,00	22138100		53015004200	5,42					53015004200	5,42
					+1,25	22138125		53015004225	5,42					53015004225	5,42
					+1,50	22138150		53015004250	5,42					53015004250	5,42

MALOSSI															
2 TEMPI - 2 STROKE															
Minarelli Yamaha Perform. Kit	75		47,00	Replica	STD	22351	39,44	52712004700	7,18	715025	2,25	72024	0,33	52712004700	7,18
					+0,40	22351040		52712004740	7,18					52712004740	7,18
					+0,80	22351080		52712004780	7,18					52712004780	7,18
					+1,00	22351100		52712004800	7,18					52712004800	7,18
Piaggio Gilera Perform. Kit	75		47,00	Replica	STD	22352	39,44	52712004700	7,18	715304	2,25	72053	0,33	52712004700	7,18
					+0,40	22352040		52712004740	7,18					52712004740	7,18
					+0,80	22352080		52712004780	7,18					52712004780	7,18
					+1,00	22352100		52712004800	7,18					52712004800	7,18
Minarelli Yamaha Perform. Kit	75		47,00	Race	STD	22353	39,44	53009804700	13,80	715025	2,25	72024	0,33	53010004740	13,80
					+0,40	22353040		53010004780	13,80					53010004780	13,80
					+0,80	22353080		53010004800	13,80					53010004800	13,80
					+1,00	22353100		53010004800	13,80					53010004800	13,80



Modello Model	CC	Anni Years	Cilindro Cylinder (mm)	Versione Version	Pistone Completo / Complete Piston			Set Segmenti / Ring Set		Spinotto / Wrist Pin		Anellino / Circlip	
					Ø mm	Codice Code	€	Codice Code	€	Codice Code	€	Codice Code	€
MALOSSI													
2 TEMPI - 2 STROKE													
Piaggio Gilera Perform. Kit	75		47,00	Race	STD	22354*	39,44	53009804700	14,46	715304	2,25	72053	0,33
					+0,40	22354040*		53010004740	13,80				
					+0,80	22354080*		53010004780	13,80				
					+1,00	22354100*		53010004800	13,80				
Piaggio Gilera Nikasil Cylinder Perform. Kit	75		47,60	Race	47,55	22606A	48,99	53010004760	13,80	715042	2,25	72025	0,33
					47,56	22606B							
					47,57	22606C							
					47,58	22606D							

MBK													
2 TEMPI - 2 STROKE													
Booster Evolis Target Fizz Sorriso Forte Nitro Flipper Ovetto	50		40,00	Replica	STD	22032	36,82	52715004000	2,54	715021	2,25	72024	0,33
								52715004000	2,54				
					+0,25	22032025		52715004025	2,54				
								52715004025	2,54				
					+0,50	22032050		52715004050	2,54				
								52715004050	2,54				
					+0,75	22032075		52715004075	2,54				
								52715004075	2,54				
+1,00	22032100	52715004100	2,54										
		52715004100	2,54										
+1,25	22032125	52715004125	2,54										
		52715004125	2,54										
+1,50	22032150	52715004150	2,54										
		52715004150	2,54										
+2,00	22032200	52715004200	2,54										
		52715004200	2,54										

MINARELLI													
2 TEMPI - 2 STROKE													
RV4 Nikasil cylinder	50		38,80	Race	38,75	21809A*	32,05	52615003880 52615003880	2,65 2,65	715034	2,25	72025	0,33
					38,76	21809B*							
					38,77	21809C*							
					38,78	21809D*							
					38,79	21809E*							
					38,80	21809F*							

* Fino ad esaurimento scorte / Limited stock



Modello Model	CC	Anni Years	Cilindro Cylinder (mm)	Versione Version	Pistone Completo / Complete Piston			Set Segmenti / Ring Set		Spinotto / Wrist Pin		Anellino / Circlip	
					Ø mm	Codice Code	€	Codice Code	€	Codice Code	€	Codice Code	€
MINARELLI													
2 TEMPI - 2 STROKE													
MY CY CW	50		40,00	Replica	STD	22032	36,82	52715004000	2,54	715021	2,25	72024	0,33
					+0,25	22032025		52715004000	2,54				
					+0,50	22032050		52715004025	2,54				
					+0,75	22032075		52715004025	2,54				
					+1,00	22032100		52715004050	2,54				
					+1,25	22032125		52715004050	2,54				
					+1,50	22032150		52715004075	2,54				
					+2,00	22032200		52715004075	2,54				
DL3 Water cooled Raffr. liquido	50		40,30	Replica	STD	22060	39,14	53015004030	5,42	715038	2,25	72025	0,33
					+0,33	22060030		52715004030	2,54				
					+0,50	22060050		53015004060	5,42				
					+0,70	22060070		52715004060	2,54				
DL3 Air cooled Raffr. aria	50		40,30	Replica	STD	22062	39,14	53015004030	5,42	715038	2,25	72025	0,33
					+0,33	22062030		52715004030	2,54				
					+0,50	22062050		53015004060	5,42				
					+0,70	22062070		52715004060	2,54				
AM 345	50		40,30	Replica	40,25	22088A	39,14	53015004030	5,42	715038	2,25	72025	0,33
					40,26	22088B							
					40,27	22088C							
					40,28	22088D							
					40,29	22088E							
					40,31	22088F							
					40,31	22088G							

MORINI FRANCO MOTORI													
2 TEMPI - 2 STROKE													
GS GSA Nikasil cylinder	50		39,00	Replica	38,986	21820A*	41,60	52710003900	5,42	715035	2,25	72025	0,33
					38,978	21820B*							
					38,970	21820C*							
					38,962	21820D*							
G30 G304 Nikasil cylinder	50		39,00	Replica	38,986	21821A	41,60	52710003900	5,42	715035	2,25	72025	0,33
					38,978	21821B							
					38,970	21821C							
					38,962	21821D							

* Fino ad esaurimento scorte / Limited stock



Modello Model	CC	Anni Years	Cilindro Cylinder (mm)	Versione Version	Pistone Completo / Complete Piston			Set Segmenti / Ring Set		Spinotto / Wrist Pin		Anellino / Circlip	
					Ø mm	Codice Code	€	Codice Code	€	Codice Code	€	Codice Code	€
MORINI FRANCO MOTORI													
2 TEMPI - 2 STROKE													
S6 Economico Cast iron cylinder	50		39,00	Replica	STD	22160	41,60	52520003900	3,65	715035	2,25	72025	0,33
					+0,50	22160050		52615003900	2,65				
					+1,00	22160100		52520003950	3,65				
								52615003950	2,65				
T4 TA Nikasil cylinder	50		39,00	Replica	39,002	22039A	41,60	52520003900	3,65	715035	2,25	72025	0,33
					38,994	22039B		52615003900	2,65				
					38,986	22039C							
					38,978	22039D							
M1 M1K M101 Nikasil cylinder	50		40,40	Replica	40,39	22016A	33,91	52715004040	2,54	715035	2,25	72025	0,33
					40,38	22016B		52715004040	2,54				
					40,37	22016C							
					40,36	22016D							
AY50 TR 50S	50		41,00	Replica	STD	22138	40,97	53015004100	5,42	715353	2,25	72024	0,33
					+0,25	22138025		53015004100	5,42				
					+0,50	22138050		53015004125	5,42				
					+0,75	22138075		53015004125	5,42				
					+1,00	22138100		53015004150	5,42				
					+1,25	22138125		53015004150	5,42				
					+1,50	22138150		53015004175	5,42				
								53015004175	5,42				
Corsaro 900-1200	1200	2006-11	107,00	Replica	106,997	22971A	408,83			711157	28,98	72094	0,33
					106,987	22971B							
					106,977	22971C							
Corsaro 1200 Enduro	1200	2006-11	107,00	Replica	106,997	23387A	408,83			711157	28,98	72094	0,33
					106,987	23387B							
					106,977	23387C							
MOTRON													
2 TEMPI - 2 STROKE													
Sting Thunder Spike Sinkro	50		40,00	Replica	STD	22032	36,82	52715004000	2,54	715021	2,25	72024	0,33
					+0,25	22032025		52715004000	2,54				
					+0,50	22032050		52715004025	2,54				
					+0,75	22032075		52715004025	2,54				
					+1,00	22032100		52715004050	2,54				
					+1,25	22032125		52715004050	2,54				
					+1,50	22032150		52715004075	2,54				
					+2,00	22032200		52715004075	2,54				
								52715004100	2,54				



Modello Model	CC	Anni Years	Cilindro Cylinder (mm)	Versione Version	Pistone Completo / Complete Piston			Set Segmenti / Ring Set		Spinotto / Wrist Pin		Anellino / Circlip		
					Ø mm	Codice Code	€	Codice Code	€	Codice Code	€	Codice Code	€	
PEUGEOT														
2 TEMPI - 2 STROKE														
SV, Geo, Buxi, Zenith, Squab, Speedlight, Elyseo, Trekker	50		39,94	Replica	39,915	22313A	38,84	52715003994	2,67	715297	2,25	72025	0,33	
					39,925	22313B								2,67
					39,935	22313C								
Metropolis	50		40,00	Replica	STD	22023*	39,14	53015004000	5,42	715021	2,25	72003	0,33	
					+0,25	22023025*		52715004000	2,54					
					+0,50	22023050*		53015004025	5,42					
					+0,75	22023075*		52715004025	2,54					
					+1,00	22023100*		53015004050	5,42					
					+1,25	22023125*		52715004050	2,54					
					+1,40	22023140*		53015004075	5,42					
					+1,50	22023150*		52715004075	2,54					
								53015004100	5,42					
		52715004100	2,54											
Rapido	50		41,00	Replica	STD	22024	37,16	53015004100	5,42	715021	2,25	72003	0,33	
					+0,25	22024025		52715004100	2,54					
					+0,50	22024050		53015004125	5,42					
					+0,75	22024075		52715004125	2,54					
					+1,00	22024100		53015004150	5,42					
					+1,25	22024125		52715004150	2,54					
					+1,50	22024150		53015004175	5,42					
								52715004175	2,54					
								53015004200	5,42					
		52715004200	2,54											
Bravo Si Boxer	50		38,20	Replica	STD	21634*	25,59	52520003820	3,65	715016	2,25	72024	0,33	
					+0,20	21634020*		52615003820	2,65					
					+0,40	21634040*		52520003840	3,65					
					+0,60	21634060*		52615003840	2,65					
					+0,80	21634080*		52520003860	3,65					
					+1,00	21634100*		52615003860	2,65					
					+1,40	21634140*		52520003880	3,65					
					+1,60	21634160*		52615003880	2,65					
					+2,00	21634200*		52520003900	3,65					
		52615003900	2,65											
		52520003920	3,65											
		52615003920	2,65											
		52520003960	3,65											
		52615003960	2,65											
		52520003980	3,65											
		52615003980	2,65											
		52520004020	3,65											
		52615004020	2,65											

* Fino ad esaurimento scorte / Limited stock



Modello Model	CC	Anni Years	Cilindro Cylinder (mm)	Versione Version	Pistone Completo / Complete Piston			Set Segmenti / Ring Set		Spinotto / Wrist Pin		Anellino / Circlip	
					Ø mm	Codice Code	€	Codice Code	€	Codice Code	€	Codice Code	€
PIAGGIO													
2 TEMPI - 2 STROKE													
Si Eco Heron	50		38,20	Replica	STD	21980*	25,59	52520003820	3,65	715352	2,25	72061	0,33
					+0,20	21980020*		52615003820	2,65				
					+0,40	21980040*		52520003840	3,65				
					+0,60	21980060*		52615003840	2,65				
					+0,80	21980080*		52520003860	3,65				
					+1,00	21980100*		52615003860	2,65				
					+1,40	21980140*		52520003880	3,65				
					+1,60	21980160*		52615003880	2,65				
					+2,00	21980200*		52520003880	3,65				
					+2,00	21980200*		52615003880	2,65				
Boxer2 Bravo2 Si Ciao	50		38,40	Replica	STD	21433*	24,04	52520003840	3,65	715033	2,25	72025	0,33
					+0,20	21433020*		52615003840	2,65				
					+0,40	21433040*		52520003860	3,65				
					+0,60	21433060*		52615003860	2,65				
					+0,80	21433080*		52520003880	3,65				
					+1,00	21433100*		52615003880	2,65				
					+1,40	21433140*		52520003900	3,65				
					+1,80	21433180*		52615003900	2,65				
					+2,00	21433200*		52520003920	3,65				
					+2,00	21433200*		52615003920	2,65				
Ape 50	50		38,40	Replica	STD	21931*	27,86	53720003840	8,28	715033	2,25	72028	0,33
					+0,20	21931020*		53720003840	8,28				
					+0,40	21931040*		53720003860	8,28				
					+0,60	21931060*		53720003860	8,28				
					+0,80	21931080*		53720003880	8,28				
					+1,00	21931100*		53720003880	8,28				
					+1,40	21931140*		53720003900	8,28				
					+1,40	21931140*		53720003900	8,28				
Vespa HP Nikasil cylinder	50		38,40	Replica	38,36	22249A	28,35	50420003840	5,85	715033	2,25	72025	0,33
					38,37	22249B							
					38,38	22249C							
					38,39	22249D							
					38,40	22249E							
					38,41	22249F							

* Fino ad esaurimento scorte / Limited stock



Modello Model	CC	Anni Years	Cilindro Cylinder (mm)	Versione Version	Pistone Completo / Complete Piston			Set Segmenti / Ring Set		Spinotto / Wrist Pin		Anellino / Circlip			
					Ø mm	Codice Code	€	Codice Code	€	Codice Code	€	Codice Code	€		
PIAGGIO															
2 TEMPI - 2 STROKE															
Sfera Zip Quarz Free NRG Liberty	50		40,00	Replica	STD	22061	25,07	52715004000	2,54	715036	2,25	72025	0,33	52715004000	2,54
					+0,20	22061020		52715004020	2,54					52715004020	2,54
					+0,40	22061040		52715004040	2,54					52715004040	2,54
					+0,60	22061060		52715004060	2,54					52715004060	2,54
					+0,80	22061080		52715004080	2,54					52715004080	2,54
					+1,00	22061100		52715004100	2,54					52715004100	2,54
					+1,40	22061140		52715004140	2,54					52715004140	2,54
					+1,60	22061160		52715004160	2,54					52715004160	2,54
					+2,00	22061200		52715004200	2,54					52715004200	2,54
Vespa PX	125		52,50	Replica	STD	21604	33,91	52525005250	4,97	711127	5,04	72023	0,33	52625005250	3,65
					+0,20	21604020		52525005270	4,97					52625005270	3,65
					+0,40	21604040		52525005290	4,97					52625005290	3,65
					+0,60	21604060		52525005310	4,97					52625005310	3,65
					+0,80	21604080		52525005330	4,97					52625005330	3,65
					+1,00	21604100		52525005350	4,97					52625005350	3,65
					+1,40	21604140		52525005390	4,97					52625005390	3,65
					+1,60	21604160		52525005410	4,97					52625005410	3,65
Vespa Primavera PKX ET3	125		55,00	Replica	STD	21659	35,74	52525005500	4,97	715105	2,69	72023	0,33	52625005500	3,65
					+0,20	21659020		52525005520	4,97					52625005520	3,65
					+0,40	21659040		52525005540	4,97					52625005540	3,65
					+0,60	21659060		52525005560	4,97					52625005560	3,65
					+0,80	21659080		52525005580	4,97					52625005580	3,65
					+1,00	21659100		52525005330	4,97					52625005330	3,65
					+1,40	21659140		52525005640	4,97					52625005640	3,65
					+1,60	21659160		52525005660	4,97					52625005660	3,65
					+2,00	21659200		52525005700	4,97					52625005700	3,65



Modello Model	CC	Anni Years	Cilindro Cylinder (mm)	Versione Version	Pistone Completo / Complete Piston			Set Segmenti / Ring Set		Spinotto / Wrist Pin		Anellino / Circlip	
					Ø mm	Codice Code	€	Codice Code	€	Codice Code	€	Codice Code	€
PIAGGIO													
2 TEMPI - 2 STROKE													
Vespa P150X P150S	150		57,80	Replica	STD	21660	38,84	52625005780	3,65	715249	3,75	72023	0,33
								52625005780	3,65				
					+0,20	21660020		52625005800	3,65				
								52625005800	3,65				
					+0,40	21660040		52625005820	3,65				
								52625005820	3,65				
					+0,60	21660060		52625005840	3,65				
		52625005840	3,65										
		+0,80	21660080	52625005860	3,65			52625005860	3,65				
		+1,00	21660100	52625005880	3,65			52625005880	3,65				
								52625005880	3,65				
Hexagon Water cooled Raffr. liquido	150		60,60	Replica	STD	22339	67,18	53015006060	19,32	715299	3,75	72027	0,33
								53015006060	19,32				
					+0,20	22339020		53015006080	19,32				
								53015006080	19,32				
					+0,40	22339040		53015006100	19,32				
								53015006100	19,32				
					+0,60	22339060		53015006120	19,32				
		53015006120	19,32										
		+0,80	22339080	53015006140	19,32			53015006140	19,32				
		+1,00	22339100	53015006160	19,32			53015006160	19,32				
								53015006160	19,32				
Skipper Air cooled Raffr. aria Nikasil cylinder	150		60,60	Replica	60,55	22392A	70,58	53015006060	19,32	715299	3,75	72027	0,33
					60,56	22392B							
					60,57	22392C							
					60,58	22392D							
Ape MP 500/550	200		63,00	Replica	STD	21076	37,30	52625006300	3,88	715137	2,69	72058	0,33
								52625006300	3,88				
					+0,20	21076020		52625006320	3,88				
								52625006320	3,88				
					+0,40	21076040		52625006340	3,88				
								52625006340	3,88				
					+0,60	21076060		52625006360	3,88				
								52625006360	3,88				
					+0,80	21076080		52625006380	3,88				
								52625006380	3,88				
+1,00	21076100	52625006400	3,88			52625006400	3,88						
		+1,40	21076140	52625006440	3,88			52625006440	3,88				
		+1,60	21076160	52625006460	3,88			52625006460	3,88				
		+2,00	21076200	52625006500	3,88			52625006500	3,88				
								52625006500	3,88				



Modello Model	CC	Anni Years	Cilindro Cylinder (mm)	Versione Version	Pistone Completo / Complete Piston			Set Segmenti / Ring Set		Spinotto / Wrist Pin		Anellino / Circlip	
					Ø mm	Codice Code	€	Codice Code	€	Codice Code	€	Codice Code	€
PIAGGIO													
2 TEMPI - 2 STROKE													
Ape Car Spinotto Pin Ø 18	250		68,00	Replica	STD	21962	45,62	53725006800	11,60	715273	4,50	72032	0,33
					+0,20	21962020		52625006800	4,08				
					+0,40	21962040		53725006820	11,60				
								52625006820	4,08				
					+0,60	21962060		53725006840	11,60				
								52625006840	4,08				
					+0,80	21962080		53725006860	11,60				
								52625006860	4,08				
					+1,00	21962100		53725006880	11,60				
								52625006880	4,08				
+1,40	21962140	53725006900	11,60										
		52625006900	4,08										
+1,60	21962160	53725006940	11,60										
		52625006940	4,08										
+2,00	21962200	53725006960	11,60										
		52625006960	4,08										
+2,40	21962240	53725007000	11,60										
		52625007000	4,08										
+3,00	21962300	53725007040	11,60										
		52625007040	4,08										
		53725007100	11,60										
		52625007100	4,08										
4 TEMPI - 4 STROKE													
Beverly X9	250		72,00	Race	71,96	23214	84,96	590372000001	49,50	715383	5,69	72049	0,33
					+0,25	23214025		590372250001					
					+0,50	23214050		590372500001					
					+0,75	23214075		590372750001					

POLINI													
2 TEMPI - 2 STROKE													
Ciao Spinotto Pin Ø 10 Perform. Kit	65		43,00	Replica	STD	21907*	33,91	52615004300	2,65	715352	2,25	72024	0,33
								52615004300	2,65				
					+0,20	21907020*		52615004320	2,65				
								52615004320	2,65				
					+0,40	21907040*		52615004340	2,65				
								52615004340	2,65				
+0,60	21907060*	52615004360	2,65										
		52615004360	2,65										
+0,80	21907080*	52615004380	2,65										
		52615004380	2,65										
+1,00	21907100*	52615004400	2,65										
		52615004400	2,65										
Ciao Spinotto Pin Ø 12 Perform. Kit	65		43,00	Replica	STD	21910*	33,91	52615004300	2,65	715035	2,25	72025	0,33
								52615004300	2,65				
					+0,20	21910020*		52615004320	2,65				
								52615004320	2,65				
					+0,40	21910040*		52615004340	2,65				
								52615004340	2,65				
+0,60	21910060*	52615004360	2,65										
		52615004360	2,65										
+0,80	21910080*	52615004380	2,65										
		52615004380	2,65										
+1,00	21910100*	52615004400	2,65										
		52615004400	2,65										

* Fino ad esaurimento scorte / Limited stock



Modello Model	CC	Anni Years	Cilindro Cylinder (mm)	Versione Version	Pistone Completo / Complete Piston			Set Segmenti / Ring Set		Spinotto / Wrist Pin		Anellino / Circlip	
					Ø mm	Codice Code	€	Codice Code	€	Codice Code	€	Codice Code	€
POLINI													
2 TEMPI - 2 STROKE													
Sfera Quarz Zip Typhoon Honda SV Spinotto Pin Ø 12 Perform. Kit	65		46,00	Replica	STD	22262*	37,91	52712004600	7,18	715042	2,25	72053	0,33
					+0,40	22262040*		52712004600	7,18				
					+0,80	22262080*		52712004640	7,18				
					+1,00	22262100*		52712004680	7,18				
					+1,40	22262140*		52712004700	7,18				
					+1,60	22262160*		52712004700	7,18				
					+2,00	22262200*		52712004740	7,18				
Vespa 90 Perform. Kit	90		47,00	Replica	STD	21744	33,91	52615004700	3,09	715047	2,25	72025	0,33
					+0,40	21744040		52615004700	3,09				
					+0,80	21744080		52615004740	3,09				
					+1,00	21744100		52615004780	3,09				
					+1,40	21744140		52615004780	3,09				
					+2,00	21744200		52615004800	3,09				
					52615004800	3,09							
Minarelli RV4 Nikasil cylinder Perform. Kit	90		47,00	Replica	46,94	21899A*	38,84	52712004700	7,18	715047	2,25	72025	0,33
					46,95	21899B*							
					46,96	21899C*							
					46,97	21899D*							
Minarelli DL3, RV4 Perform. Kit	90		47,00	Replica	STD	22134*	40,97	52712004700	7,18	715047	2,25	72025	0,33
					+0,40	22134040*		52712004700	7,18				
					+0,80	22134080*		52712004740	7,18				
					+1,00	22134100*		52712004780	7,18				
								52712004800	7,18				
Sfera Quarz, Zip Typhoon Honda SV Spinotto/Pin Ø 12 Perform. Kit	90		47,00	Replica	STD	22273	35,14	53012004700	11,81	715042	2,25	72053	0,33
					+0,40	22273040		53012004740	11,81				
					+0,80	22273080		53012004780	11,81				
					+1,00	22273100		53012004800	11,81				
Minarelli Yamaha Spinotto/Pin Ø 10 Perform. Kit	90		47,00	Replica	STD	22274	35,14	53012004700	11,81	715367	2,25	72024	0,33
					+0,40	22274040		53012004740	11,81				
					+0,80	22274080		53012004780	11,81				
					+1,00	22274100		53012004800	11,81				

* Fino ad esaurimento scorte / Limited stock



Modello Model	CC	Anni Years	Cilindro Cylinder (mm)	Versione Version	Pistone Completo / Complete Piston			Set Segmenti / Ring Set		Spinotto / Wrist Pin		Anellino / Circlip	
					Ø mm	Codice Code	€	Codice Code	€	Codice Code	€	Codice Code	€
POLINI													
2 TEMPI - 2 STROKE													
Minarelli Yamaha Spinotto/Pin Ø 10 Perform. Kit	90		47,00	Replica	STD	22275	40,97	53009804700	14,46	715367	2,25	72024	0,33
					+0,40	22275040		53010004740	14,46				
					+0,80	22275080		53010004740	14,46				
					+1,00	22275100		53010004780	14,46				
								53010004780	14,46				
Minarelli AM345 Nikasil cylinder Perform. Kit	90		47,00	Replica	46,95	22423A	37,91	53009804700	14,46	715047	2,25	72053	0,33
					46,96	22423B							
					46,97	22423C							
					46,98	22423D							
					46,99	22423E							
					47,00	22423F							
Honda Piaggio Perform. Kit	90		47,00	Replica	STD	22424	37,91	53009804700	14,46	715042	2,25	72053	0,33
					+0,40	22424040		53010004740	14,46				
					+0,80	22424080		53010004740	14,46				
					+1,00	22424100		53010004780	14,46				
								53010004780	14,46				
Yamaha MBK Nikasil cylinder Perform. Kit	90		47,00	Replica	46,95	22425A	35,14	53012004700	11,81	715367	2,25	72024	0,33
					46,96	22425B							
					46,97	22425C							
					46,98	22425D							
					46,99	22425E							
					47,00	22425F							
Minarelli Yamaha Nikasil cylinder Perform. Kit	90		47,60	Replica	47,55	22560A	40,97	53010004760	13,80	715025	2,25	72024	0,33
					47,56	22560B							
					47,57	22560C							
					47,58	22560D							
Piaggio Gilera Nikasil cylinder Perform. Kit	90		47,60	Replica	47,55	22561A	40,97	53010004760	13,80	715042	2,25	72025	0,33
					47,56	22561B							
					47,57	22561C							
					47,58	22561D							
Vespa 100cc Perform. Kit	100		55,00	Replica	STD	21623*	41,60	52715005500	3,75	715047	2,25	72025	0,33
					+0,20	21623020*		52715005500	3,75				
					+0,40	21623040*		52715005520	3,75				
					+0,60	21623060*		52715005520	3,75				
					+0,80	21623080*		52715005540	3,75				
					+1,00	21623100*		52715005540	3,75				
					+1,20	21623120*		52715005560	3,75				
					+1,60	21623160*		52715005560	3,75				
					+1,80	21623180*		52715005580	3,75				
								52715005580	3,75				

* Fino ad esaurimento scorte / Limited stock



Modello Model	CC	Anni Years	Cilindro Cylinder (mm)	Versione Version	Pistone Completo / Complete Piston			Set Segmenti / Ring Set		Spinotto / Wrist Pin		Anellino / Circlip	
					Ø mm	Codice Code	€	Codice Code	€	Codice Code	€	Codice Code	€
POLINI													
2 TEMPI - 2 STROKE													
Vespa 100cc Perform. Kit	100		55,00	Replica	STD	21624	40,68	52715005500	3,75	715047	2,25	72025	0,33
					+0,40	21624040		52715005500	3,75				
					+0,80	21624080		52715005540	3,75				
					+1,00	21624100		52715005540	3,75				
					+1,40	21624140		52715005580	3,75				
					+1,60	21624160		52715005580	3,75				
					+2,00	21624200		52715005600	3,75				
Vespa ET3 Middle port Luce bassa Perform. Kit	125		57,00	Replica	STD	21635	43,76	52715005640	3,75	715249	3,75	72023	0,33
					+0,40	21635040		52715005600	3,75				
					+0,80	21635080		52715005740	3,75				
					+1,00	21635100		52715005740	3,75				
					+1,40	21635140		52715005780	3,75				
					+1,60	21635160		52715005780	3,75				
					+2,00	21635200		52715005800	3,75				
Honda Nikasil cylinder Perform. Kit	200		64,00	Replica	63,95	21903A*	66,57	52712006400	12,69	715258	2,58	72058	0,33
					63,96	21903B*							
					63,97	21903C*							
					63,98	21903D*							
					63,99	21903E*							
					64,00	21903F*							
64,01	21903G*												

RIZZATO													
2 TEMPI - 2 STROKE													
Carosello	50		40,00	Replica	STD	22032	36,82	52715004000	2,54	715021	2,25	72024	0,33
					+0,25	22032025		52715004000	2,54				
					+0,50	22032050		52715004025	2,54				
					+0,75	22032075		52715004025	2,54				
					+1,00	22032100		52715004050	2,54				
					+1,25	22032125		52715004050	2,54				
					+1,50	22032150		52715004075	2,54				
					+2,00	22032200		52715004075	2,54				

* Fino ad esaurimento scorte / Limited stock



Modello Model	CC	Anni Years	Cilindro Cylinder (mm)	Versione Version	Pistone Completo / Complete Piston			Set Segmenti / Ring Set		Spinotto / Wrist Pin		Anellino / Circlip	
					Ø mm	Codice Code	€	Codice Code	€	Codice Code	€	Codice Code	€
RIZZATO													
2 TEMPI - 2 STROKE													
Hacker Byte AT10 Skeggia	50		41,00	Replica	STD	22138	40,97	53015004100	5,42	715353	2,25	72024	0,33
					+0,25	22138025		53015004100	5,42				
					+0,50	22138050		53015004125	5,42				
					+0,75	22138075		53015004125	5,42				
					+1,00	22138100		53015004150	5,42				
					+1,25	22138125		53015004150	5,42				
					+1,50	22138150		53015004175	5,42				
								53015004175	5,42				
		53015004200	5,42										
		53015004200	5,42										
		53015004225	5,42										
		53015004225	5,42										
		53015004250	5,42										
		53015004250	5,42										

ROTAX													
2 TEMPI - 2 STROKE													
Tuareg Nikasil Cylinder	125		54,00	Replica	53,93	21842A	88,14	53010005400	16,01	711127	5,04	72049	0,33
					53,94	21842B							
					53,95	21842C							
					53,96	21842D							
					53,97	21842E							
					53,98	21842F							
					53,99	21842G							
					54,00	21842H							
		54,01	21842I										
Tuareg Cast Iron Cylinder	125		54,00	Replica	STD	21938	90,60	53010005400	16,01	711127	5,04	72049	0,33
					+0,25	21938025		53010005400	16,01				
					+0,50	21938050		53010005425	16,01				
					+0,75	21938075		53010005425	16,01				
					+1,00	21938100		53010005450	16,01				
					+1,25	21938125		53010005450	16,01				
					+1,50	21938150		53010005475	16,01				
								53010005475	16,01				
		53010005500	16,01										
		53010005500	16,01										
		53010005525	16,01										
		53010005525	16,01										
		53010005550	16,01										
		53010005550	16,01										
Futura, AF1, RX, Red Rose, Rally, Syntesi, Pegaso, Tuareg Europe, Replica, RS125 Nikasil Cylinder	125		54,00	Replica	53,97	22003A	91,23	53010005400	16,01	711127	5,04	72049	0,33
					53,98	22003B							
					53,99	22003C							
					54,00	22003D							
					54,01	22003E							
					54,02	22003F							
Extrema, Sport Production RS125 Nikasil Cylinder	125		54,00	Race	53,93	22261A	91,53	53010005400	16,01	711127	5,04	72049	0,33
					53,94	22261B							
					53,95	22261C							
					53,96	22261D							
					53,97	22261E							
					53,98	22261F							

* Fino ad esaurimento scorte / Limited stock



Modello Model	CC	Anni Years	Cilindro Cylinder (mm)	Versione Version	Pistone Completo / Complete Piston			Set Segmenti / Ring Set		Spinotto / Wrist Pin		Anellino / Circlip	
					Ø mm	Codice Code	€	Codice Code	€	Codice Code	€	Codice Code	€
ROTAX													
2 TEMPI - 2 STROKE													
GP250 Bicilindrico Twin	250		54,00	Replica	53,93	22428A	88,14	53010005400	16,01	711127	5,04	72049	0,33
					53,94	22428B							
					53,95	22428C							
					53,96	22428D							
					53,97	22428E							
					53,98	22428F							
SUZUKI													
2 TEMPI - 2 STROKE													
AY50 TR 50S Address Sepia ZZ AJ	50		41,00	Replica	STD	22138	40,97	53015004100	5,42	715353	2,25	72024	0,33
					+0,25	22138025		53015004100	5,42				
					+0,50	22138050		53015004125	5,42				
					+0,75	22138075		53015004125	5,42				
					+1,00	22138100		53015004150	5,42				
					+1,25	22138125		53015004150	5,42				
					+1,50	22138150		53015004175	5,42				
								53015004175	5,42				
RMX 5M	50		41,00	Replica	STD	22491	40,97	53015004100	5,42	715040	2,25	72053	0,33
					+0,25	22491025		52715004100	2,54				
					+0,50	22491050		53015004125	5,42				
					+0,75	22491075		52715004125	2,54				
					+1,00	22491100		53015004150	5,42				
					+1,25	22491125		52715004150	2,54				
					+1,50	22491150		53015004175	5,42				
								52715004175	2,54				
RGV Bicilindrico Twin	250		56,00	Replica	55,94	22796A	101,43	53010005600	16,01	715061	2,69	72027	0,33
					55,95	22796B							
					55,96	22796C							
					55,97	22796D							
					55,98	22796E							
RGV Bicilindrico Twin 1 ring/segm.	250		56,00	Race	55,94	22800A	101,43	53010005600	16,01	715061	2,69	72027	0,33
					55,95	22800B							
					55,96	22800C							
					55,97	22800D							
						22800D							
4 TEMPI - 4 STROKE													
Burgmann	400		83,00	Race	82,95	23210	134,44	590383000002	52,27	711141	8,38	72073	0,33
					+0,50	23210050		590383500002					
					+1,00	23210100		590384000002					
SYM													
2 TEMPI - 2 STROKE													
Jungle Jet Cha Red Devil Super Fancy	50		39,00	Replica	STD	22383	40,68	53015003900	5,42	715240	2,25	72025	0,33
					+0,25	22383025		53015003900	5,42				
					+0,50	22383050		53015003925	5,42				
					+0,75	22383075		53015003925	5,42				
					+1,00	22383100		53015003950	5,42				
								53015003950	5,42				



Modello Model	CC	Anni Years	Cilindro Cylinder (mm)	Versione Version	Pistone Completo / Complete Piston			Set Segmenti / Ring Set		Spinotto / Wrist Pin		Anellino / Circlip	
					Ø mm	Codice Code	€	Codice Code	€	Codice Code	€	Codice Code	€
TOP PERFORMANCES													
2 TEMPI - 2 STROKE													
Minarelli Yamaha Perform. Kit	70		46,00	Replica	STD	22372	38,84	52915004600	11,37	715025	2,25	72024	0,33
					+0,40	22372040		52915004600	11,37				
					+0,80	22372080		52915004640	11,37				
					+1,00	22372100		52915004680	11,37				
					+1,40	22372140		52915004680	11,37				
					+1,80	22372180		52915004700	11,37				
					+2,00	22372200		52915004700	11,37				
Minarelli Yamaha vertical & horizontal cyl. Cilin. verticale e orizzontale Perform. Kit	70		47,00	Replica	STD	22373	42,53	52915004700	11,37	715025	2,25	72024	0,33
					+0,40	22373040		52915004740	11,37				
					+0,80	22373080		52915004780	11,37				
					+1,00	22373100		52915004800	11,37				
Honda Peugeot Perform. Kit	75		47,00	Replica	STD	22374	32,66	52615004700	3,09	715042	2,25	72025	0,33
					+0,40	22374040		52615004700	3,09				
					+0,80	22374080		52615004740	3,09				
					+1,00	22374100		52615004780	3,09				
Sfera Typhoon Perform. Kit	75		48,00	Replica	STD	22362	35,14	52915004800	11,37	715336	2,25	72025	0,33
					+0,40	22362040		52915004800	11,37				
					+0,80	22362080		52915004840	11,37				
					+1,00	22362100		52915004880	11,37				
								52915004880	11,37				
YAMAHA													
2 TEMPI - 2 STROKE													
Aerox	50	2000-09	40,00	Replica	STD	22032	36,82	52715004000	2,54	715021	2,25	72024	0,33
					+0,25	22032025		52715004000	2,54				
					+0,50	22032050		52715004025	2,54				
					+0,75	22032075		52715004025	2,54				
					+1,00	22032100		52715004050	2,54				
					+1,25	22032125		52715004050	2,54				
					+1,50	22032150		52715004075	2,54				
					+2,00	22032200		52715004075	2,54				
CT 50S Breeze CRZ	50		40,00	Replica	STD	22081	36,92	52915004000	5,55	715021	2,25	72024	0,33
					+0,25	22081025		52915004000	5,55				
					+0,50	22081050		52915004025	5,55				
					+0,75	22081075		52915004050	5,55				
					+1,00	22081100		52915004050	5,55				



Modello Model	CC	Anni Years	Cilindro Cylinder (mm)	Versione Version	Pistone Completo / Complete Piston			Set Segmenti / Ring Set		Spinotto / Wrist Pin		Anellino / Circlip		
					Ø mm	Codice Code	€	Codice Code	€	Codice Code	€	Codice Code	€	
YAMAHA														
2 TEMPI - 2 STROKE														
DT	65		43,00	Replica	STD	22222	38,84	52915004300	5,55	715041	2,25	72025	0,33	
					+0,50	22222050		52915004350	5,55					
					+1,00	22222100		52915004400	5,55					
					+1,50	22222150		52915004450	5,55					
					+2,00	22222200		52915004500	5,55					
TDR TRZ DT	125		56,00	Replica	STD	22140	90,29	53010005600	16,01	715242	2,69	72055	0,33	
					+0,25	22140025		53010005625	16,01					
					+0,50	22140050		53010005650	16,01					
					+0,75	22140075		53010005675	16,01					
					+1,00	22140100		53010005700	16,01					
4 TEMPI - 4 STROKE														
TTR XT125R Air Cooled Raf. Aria	125		54,00	Replica	53,97	23349	108,16	590354000001	38,03	715262	2,69	72049	0,33	
					+0,25	23349025		590354250001						
					+0,50	23349050		590354500001						
					+2,00	23349200		590356000001						
YZF 125R R125 race Liquid Cooled Raffr. Liquido	125		52,00	H.C. Race	51,96	23516A	108,16	590352000001	38,03	715029	4,35	72050	0,33	
					51,97	23516B								
					51,98	23516C								
Majesty	125		53,70	Race	53,67	23221	133,91	590353700001	41,25	715262	2,69	72049	0,33	
					+0,25	23221025		590353950001						
					+0,50	23221050		590354200001						
Majesty	250		69,00	Race	68,97	23208	126,41	590369000001	45,53	711159	5,69	72092	0,33	
					+0,50	23208050		590369500001						
					+1,00	23208100		590370000001						
Versity	250		71,00	Race	70,97	23208200	138,73	590371000001	48,74	711159	5,69	72092	0,33	
T-Max	500	2001-03	66,00	Race	65,96	23209A	153,72	590366000001	48,74	715242	2,69	72055	0,33	
YZF- R1 FZ1	1000		74,00	Replica	73,97	23011A	137,70	590374000001	23,74	711159	5,69	72092	0,33	
					73,98	23011B								
					73,99	23011C								
					74,47	23011050								590374500001
					74,97	23011100								590375000001



GO - KART PISTONS
Pistoni Go-Kart

3





Modello Model	CC	Cilindro Cylinder (mm)	Pistone Completo / Complete Piston			Set Segmenti / Ring Set		Spinotto / Wrist Pin		Anellino / Circlip	
			Ø mm	Codice Code	€	Codice Code	€	Codice Code	€	Codice Code	€
COMER IAME ITALSISTEM PCR ROTAX VORTEX											
100 cc L ring - Segm. 2 mm	100	50,00	49,850	22815A	68,71	50420004995					
			49,860	22815B							
			49,870	22815C							
			49,880	22815D							
			49,890	22815E							
			49,900	22815F							
			49,910	22815G							
			49,920	22815H							
			49,930	22815I							
			49,940	22815J							
			49,950	22815K							
			49,960	22815L							
			49,970	22815M							
			49,980	22815N							
			49,990	22815O							
			50,000	22815P							
			50,010	22815Q							
			50,020	22815R							
			50,030	22815S							
			50,040	22815T							
			50,050	22815U							
			50,060	22815V							
			50,070	22815W							
			50,080	22815X							
			50,090	22815Y							
			50,100	22815Z							
			50,110	22815ZA							
			50,120	22815ZB							
			50,130	22815ZC							
			50,140	22815ZD							
			50,150	22815ZE							
			50,160	22815ZF							
			50,170	22815ZG							
			50,180	22815ZH							
			50,190	22815ZI							
			50,200	22815ZJ							
			50,210	22815ZK							
			50,220	22815ZL							
			50,230	22815ZM							
			50,240	22815ZN							
50,250	22815ZO										
50,260	22815ZP										
50,270	22815ZQ										
50,280	22815ZR										
50,290	22815ZS										
50,300	22815ZT										
50,310	22815ZU										
50,320	22815ZV										
50,330	22815ZW										
50,340	22815ZX										
50,350	22815ZY										
50,360	22815ZZ										
50,400	22815ZZA										
50,450	22815ZZB										
50,500	22815ZZC										
50,550	22815ZZD										
50,600	22815ZZE										
50,700	22815ZZF										
50,800	22815ZZG										
50,900	22815ZZH										
51,000	22815ZZI										
51,200	22815ZZJ										
51,400	22815ZZK										



Modello Model	CC	Cilindro Cylinder (mm)	Pistone Completo / Complete Piston			Set Segmenti / Ring Set		Spinotto / Wrist Pin		Anellino / Circlip	
			Ø mm	Codice Code	€	Codice Code	€	Codice Code	€	Codice Code	€
COMER IAME ITALSISTEM PCR ROTAX VORTEX											
100cc L ring - Segm. 1,5mm	100	50,00	49,850	22817A	68,71	50415004995					
			49,860	22817B							
			49,870	22817C							
			49,880	22817D							
			49,890	22817E							
			49,900	22817F							
			49,910	22817G							
			49,920	22817H							
			49,930	22817I							
			49,940	22817J							
			49,950	22817K							
			49,960	22817L							
			49,970	22817M							
			49,980	22817N							
			49,990	22817O							
			50,000	22817P							
			50,010	22817Q							
			50,020	22817R							
			50,030	22817S							
			50,040	22817T							
			50,050	22817U							
			50,060	22817V							
			50,070	22817W							
			50,080	22817X							
			50,090	22817Y							
			50,100	22817Z							
			50,110	22817ZA							
			50,120	22817ZB							
			50,130	22817ZC							
			50,140	22817ZD							
			50,150	22817ZE							
			50,160	22817ZF							
			50,170	22817ZG							
			50,180	22817ZH							
			50,190	22817ZI							
			50,200	22817ZJ							
			50,210	22817ZK							
			50,220	22817ZL							
			50,230	22817ZM							
			50,240	22817ZN							
50,250	22817ZO										
50,260	22817ZP										
50,270	22817ZQ										
50,280	22817ZR										
50,290	22817ZS										
50,300	22817ZT										
50,310	22817ZU										
50,320	22817ZV										
50,330	22817ZW										
50,340	22817ZX										
50,350	22817ZY										
50,360	22817ZZ										
50,400	22817ZZA										
50,450	22817ZZB										
50,500	22817ZZC										
50,550	22817ZZD										
50,600	22817ZZE										
50,700	22817ZZF										
50,800	22817ZZG										
50,900	22817ZZH										
51,000	22817ZZI										
51,200	22817ZZJ										
51,400	22817ZZK										



Modello Model	CC	Cilindro Cylinder (mm)	Pistone Completo / Complete Piston			Set Segmenti / Ring Set		Spinotto / Wrist Pin		Anellino / Circlip	
			Ø mm	Codice Code	€	Codice Code	€	Codice Code	€	Codice Code	€
IAME											
Sudam	125	54,00	53,910	22691A	88,14	50420005400	23,74	715286	5,04	72050	0,31
			53,930	22691B							
			53,960	22691C							
			53,980	22691D							
			54,010	22691E							
			54,030	22691F							
			54,060	22691G							
			54,080	22691H							
			54,110	22691I							
			54,130	22691L							
			54,160	22691M							
			54,180	22691N							
			54,200	22691O							
			54,230	22691P							
54,260	22691Q										
54,290	22691R										
ROTAX											
125cc dome testa bombata 3,31 mm	125	54	53,930	21842A	88,14	53010005400	15,46	711127	5,04	72049	0,31
			53,940	21842B							
			53,950	21842C							
			53,960	21842D							
			53,970	21842E							
			53,980	21842F							
			53,990	21842G							
			54,000	21842H							
125cc dome testa bombata 2,00 mm	125	54	53,930	22428A	88,14	53010005400	15,46	711127	5,04	72049	0,31
			53,940	22428B							
			53,950	22428C							
			53,960	22428D							
			53,970	22428E							
			53,980	22428F							
M129	125	54	53,930	22434A	88,14	53010005400	15,46	711127	5,04	72049	0,31
			53,940	22434B							
			53,950	22434C							
			53,960	22434D							
			53,970	22434E							
			53,980	22434F							
MAX	125	54	53,970	23250A	88,14	53010005400	15,46	711127	5,04	72049	0,31
			53,980	23250B							
			53,990	23250C							
			54,000	23250D							
VORTEX											
ROK	125	54	53,950	23248A	88,14	53009805400	15,46	715286	5,04	72093	0,31
			53,970	23248B							
			54,000	23248C							
			54,020	23248D							
			54,050	23248E							
			54,100	23248F							
			54,150	23248G							

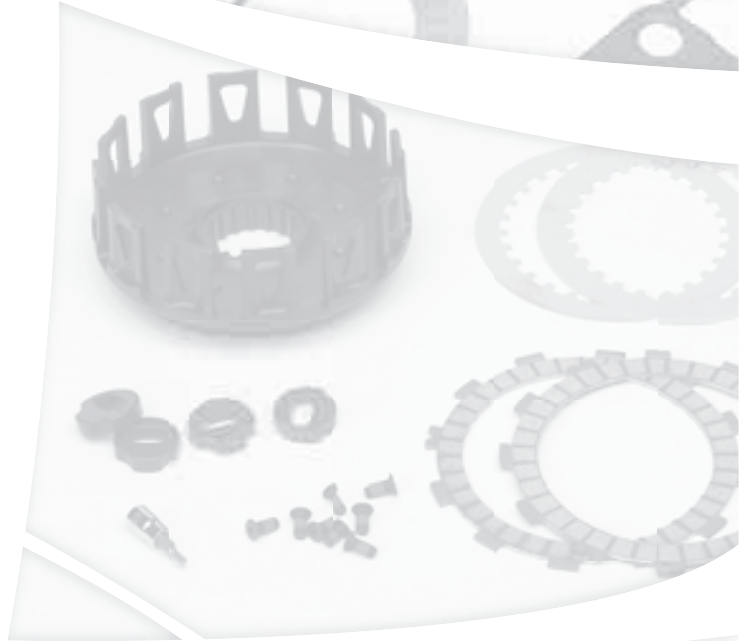
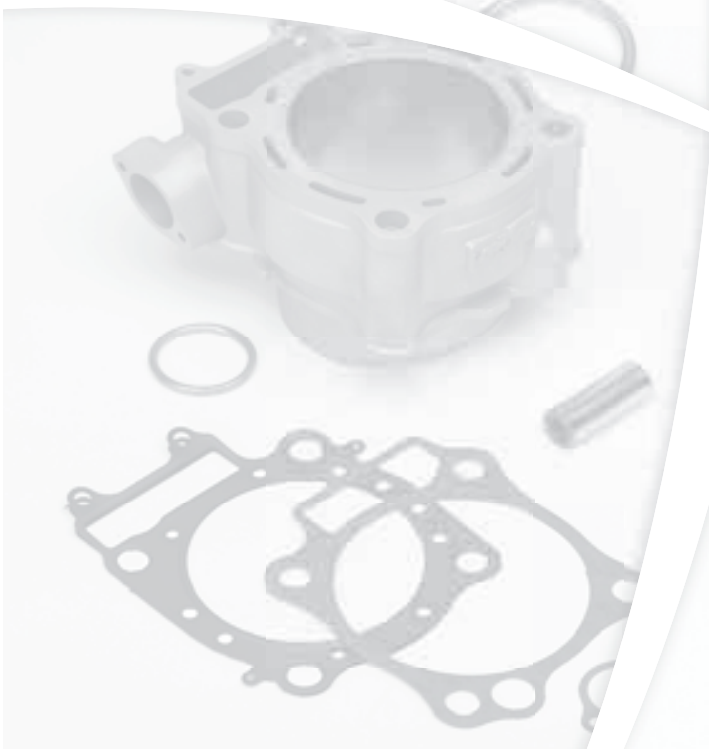
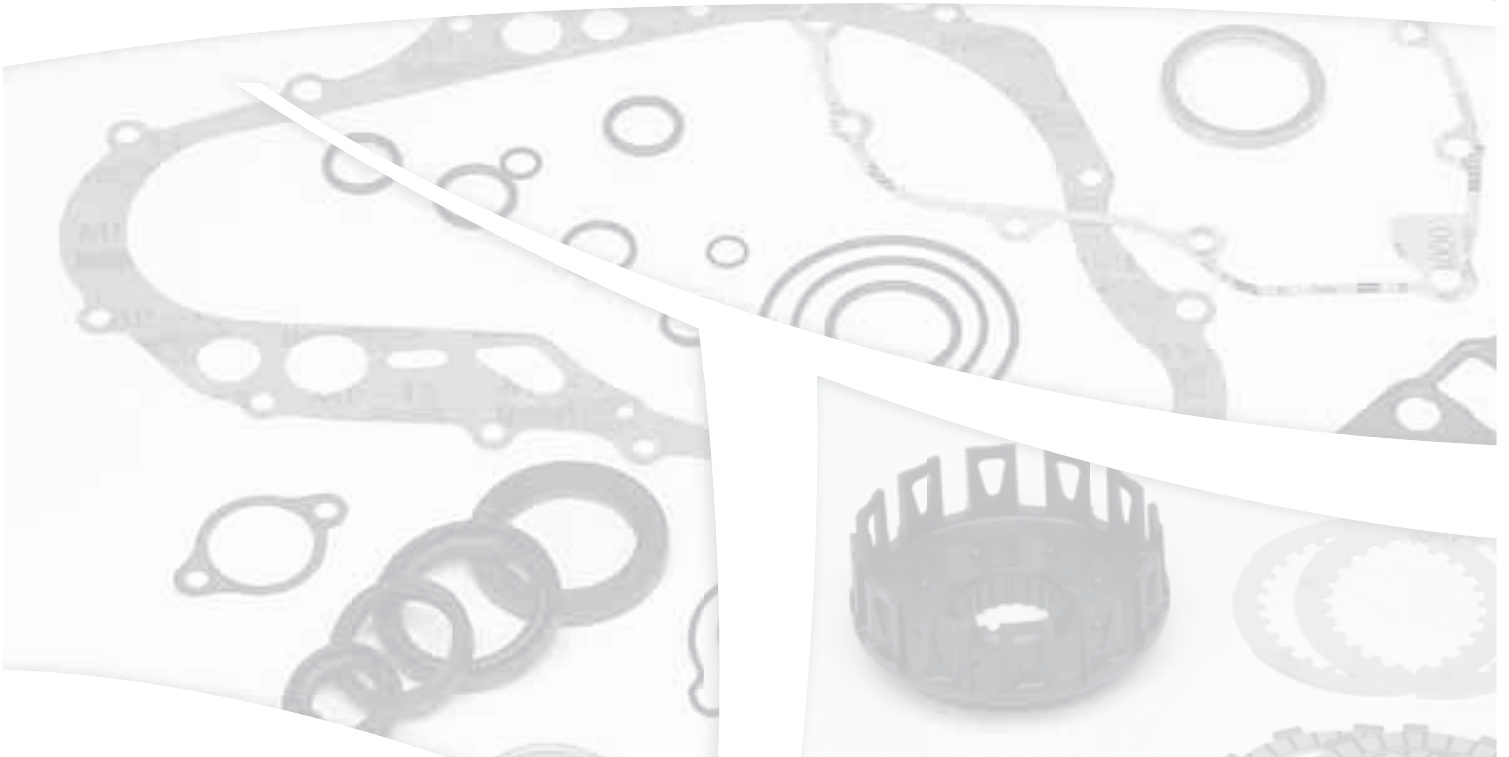



PERSONAL WATERCRAFT PISTONS
Pistoni Moto d'Acqua

4



VERTEX
PISTON & POWER





Modello Model	CC	Anni Years	Cilindro Cylinder (mm)	Versione Version	Pistone Completo / Complete Piston		
					Ø mm	Codice Code	€
KAWASAKI							
2 TEMPI - 2 STROKE							
JS440	440	1976-92	68,00	Replica	STD	8500001	102,26
					+0,25	8500001025	
					+0,75	8500001075	
					+1,00	8500001100	
					+1,25	8500001125	
					+1,50	8500001150	
					+1,75	8500001175	
JS550 JS550SX	550	1982-88 1989-95	75,00	Replica	+1,25	8500003125	102,26
					+1,75	8500003175	
					+2,00	8500003200	
800SX-R	800	2003-06	82,00	Replica	STD	8500008	110,46
					+0,25	8500008025	
					+0,50	8500008050	
					+0,75	8500008075	
900ZXi 900STX 900STS	900	1995-97 1997-06 2001-02	73,00	Replica	STD	8500002	102,26
					+0,50	8500002050	
					+0,75	8500002075	
					+1,00	8500002100	
					+1,50	8500002150	
1100ZXi 1100STX 1100STX D.I. Ultra 130 D.I.	1100	1996-03 1997-99 2000-03 2001-04	80,00	Replica	STD	8500006*	110,46
					+0,50	8500006050	
					+1,00	8500006100	
					+1,50	8500006150*	
1200 Ultra 150 STX-R 1200	1200	1999-05 2002-05	80,00	Replica & Big Bore Cylinder sleeving required for oversizes	79,87	8500007A*	110,46
					79,88	8500007B*	
					79,89	8500007C*	
					79,90	8500007D	
					+0,50	8500007050	
					+1,00	8500007100	
JS750SS Supersport 750SX ST XiR	750	1995-96 1993-95 1992-95 1994-95 1994	80,00	Replica	STD	8500009	110,46
					+0,25	8500009025	
					+0,50	8500009050	
					+0,75	8500009075	
					+1,00	8500009100	
					+1,50	8500009150	
JS750SXi 750STS 750SS Supersport Xi 750ZXi 750STX Xi Sport 750SXi Pro	750	1995-96 1995-97 1996-97 1996-97 1995-97 1998 1998-99 1998-02	80,00	Replica	STD	8500006*	110,46
					+0,50	8500006050	
					+1,00	8500006100	
					+1,50	8500006150*	

* case machining needed/necessaria lavorazione basamento ·



Modello Model	CC	Anni Years	Cilindro Cylinder (mm)	Versione Version	Pistone Completo / Complete Piston		
					Ø mm	Codice Code	€
SEA D00							
2 TEMPI - 2 STROKE							
SD580	581	1988-96	76,00	Replica	STD	8500011	102,26
					+0,25	8500011025	
					+0,50	8500011050*	
					+0,75	8500011075*	
					+1,00	8500011100	
					+1,50	8500011150*	
SD720 XP GTI HX SPX GTS GS GSI	717	1995-05	82,00	Replica	STD	8500012	102,26
					+0,25	8500012025	
					+0,50	8500012050	
					+0,75	8500012075	
					+1,00	8500012100	
					+1,50	8500012150	
SD785 XP SPX GSX GTX GTX-RFI GTI GSX-RFI	787	1995-05	82,00	Replica	STD	8500013	102,26
					+0,25	8500013025	
					+0,50	8500013050	
					+0,75	8500013075	
					+1,00	8500013100*	
					+1,50	8500013150	
SD950 GSX-LTD XP-LTD GTX-LTD LRV RX	951	1997-05	88,00	Replica	STD	8500014	109,07
					+0,25	8500014025	
					+0,50	8500014050	
					+0,75	8500014075	
					+1,00	8500014100	
					+1,50	8500014150	

YAMAHA							
2 TEMPI - 2 STROKE							
Superjet650 WaveRunner650	650	1990-93 1990-96	77,00	Replica	+0,75	8500005075	102,26
					+1,00	8500005100*	
					+1,25	8500005125	
Superjet650 WaveRunner650	700	1990-93 1990-96	81,00	Big Bore	STD	8500010	102,26
					+0,25	8500010025	
					+0,50	8500010050	
					+0,75	8500010075	
					+1,00	8500010100	
					+1,50	8500010150	
Superjet700 WaveBlaster700 WaveRaider700 WaveRunner700 WaveVenture700 XL700	700	1994-06 1993-04 1994-97 1993-04 1995-04 1995-05	81,00	Replica	STD	8500010	102,26
					+0,25	8500010025	
					+0,50	8500010050	
					+0,75	8500010075	
					+1,00	8500010100	
					+1,50	8500010150	
					+2,00	8500010200	

* case machining needed/necessaria lavorazione basamento ·



Modello Model	CC	Anni Years	Cilindro Cylinder (mm)	Versione Version	Pistone Completo / Complete Piston		
					Ø mm	Codice Code	€
YAMAHA							
2 TEMPI - 2 STROKE							
GP760 WaveBlaster760 WaveRaider760 WaveRunner760 WaveVenture760 XL760	760	1996-00 1996-00 1996-00 1996-00 1996-00 1996-00	84,00	Replica	STD	8500016	102,26
					+0,25	8500016025	
					+0,50	8500016050	
					+0,75	8500016075	
					+1,00	8500016100	
					+1,50	8500016150	
GP800R XL800 XLT800	800	1998-05 2000-01 2002-04	80,00	Replica & Big Bore Cylinder sleeving required for oversizes	79,90	8500017A	109,99
					79,91	8500017B	
					79,92	8500017C	
					79,93	8500017D	
					+0,50	8500017050	
					+1,00	8500017100	
WaveRunner1100 WaveVenture1100 triple	1100	1995-97	81,00	Replica	STD	8500010	102,26
					+0,25	8500010025	
					+0,50	8500010050	
					+0,75	8500010075	
					+1,00	8500010100	
					+1,50	8500010150	
GP1200 XL1200 SUV1200 triple	1200	1997-99 1997-99 1999-04	84,00	Replica	STD	8500016	102,26
					+0,25	8500016025	
					+0,50	8500016050	
					+0,75	8500016075	
					+1,00	8500016100	
					+1,50	8500016150	
XL1200LTD GP1200R XLT1200 triple	1200	1998-01 2000-03 2001-05	80,00	Replica & Big Bore Cylinder sleeving required for oversizes	79,90	8500017A	109,99
					79,91	8500017B	
					79,92	8500017C	
					79,93	8500017D	
					+0,50	8500017050	
					+1,00	8500017100	
GP1300R triple	1300	2003-06	84,00	Replica & Big Bore Cylinder sleeving required for oversizes	83,90	8500018A	178,57
					83,91	8500018B	
					83,92	8500018C	
					+0,50	8500018050	
					+1,00	8500018100	
4 TEMPI - 4 STROKE							
FX140 FX140 Cruiser	1400	2003-06	74,00	Replica & Big Bore Cylinder sleeving required for oversizes	73,97	23011A	137,70
					73,98	23011B	
					73,99	23011C	
					+0,50	23011050	
					+1,00	23011100	



CYLINDER KITS
Kit Cilindri

5





Modello Model	Anni Years	Cilindro Cylinder (mm)	CC	Kit Cilindro / Cylinder Kit		Pistone / Piston		Set Guarnizioni / Gasket Set	
				Codice Code	€	Codice Code	€	Codice Code	€
HONDA									
CRF 150R	2007-09	66	150	420021	559,95	23304B	136,58	860VG810014	74,99
		72*	180	420022	599,95	23309600	145,00	860VG810015	89,53
CRF 250R	2004-09	80	260	420018	599,95	22983200	160,88	860VG810003	84,36
		85*	300	420023	830,00	23318700	160,88	860VG810013	89,53
CRF 250R	2008-09	78	250	420030	559,95	23444B	160,88	860VG810262	71,16
CRE F 250X	2004-11	78	250	420013	559,95	23113B	160,88	860VG810262	71,16
		80	260	420018	599,95	22983200	160,88	860VG810003	84,36
		85*	300	420023	830,00	23318700	160,88	860VG810013	89,53
CRF 450R	2002-08	100	490	420004	599,95	22966400	172,68	860VG810001	93,67
CRE 450X	2002-11	100	490	420004	599,95	22966400	172,68	860VG810001	93,67

HUSABERG									
FE 450E	2009-11	102	520	420025	890,00	23368700	192,06	860VG810016	96,98

KAWASAKI									
KX 250F KXE250F	2004-06	77	250	420009	559,95	23114B	160,88	860VG810463	56,04
		77	250	420024	559,95	23259B	149,18	860VG810463	56,04
KX 250F KXE250F	2007-08	77	250	420024	559,95	23259B	149,18	860VG810463	56,04
		83	290	420019	599,95	23245600	160,88	860VG810005	84,36
KX 250F KXE250F	2004-08	84*	300	420010	599,95	23231700	160,88	860VG810006	84,36

KTM									
SX 250F	2006-11	80	280	420015	850,00	23274A	171,25	860VG810011	84,36
		84*	305	420016	875,00	23296800	171,25	860VG810012	84,36
EXC250F	2007-11	80	280	420015	850,00	23274400	171,25	860VG810011	84,36
		84*	305	420016	875,00	23296800	171,25	860VG810012	84,36
EXC400	2009-11	102	520	420025	890,00	23368700	193,09	860VG810016	96,98
EXC450R	2008-11	102	520	420025	890,00	23368700	193,09	860VG810016	96,98
EXC530R	2008-11	102	590	420026	890,00	23369700	193,09	860VG810016	96,98

SUZUKI									
RMZ 250	2004-06	77	250	420009	559,95	23114B	160,88	860VG810463	56,04
		83	290	420019	599,95	23245600	160,88	860VG810005	84,36
		84*	300	420010	599,95	23231700	160,88	860VG810006	84,36
RMZ 450	2005-07	95,5	450	420001	559,95	23199B	172,68	860VG810590	69,37
		100***	500	420002	599,95	23200450	172,68	860VG810002	96,98

YAMAHA									
YZ 250F	2001-07	77	250	420011	559,95	22812C	160,88	860VG810671	49,45
YZ 250F	2008-11	77	250	420032	559,95	23394C	160,88	860VG810671	49,45
WR250F	2001-11	77	250	420011	559,95	22812C	160,88	860VG810671	49,45
YZ 250F WR250F	2001-11	84	300	420012	830,00	23233700	160,88	860VG810008	84,36
WR450F	2006-11	95	450	420005	559,95	22896C	172,68	860VG810010	67,69
		100*	500	420006	599,95	23270500	172,68	860VG810009	93,67
YZ 450F	2006-09	95	450	420005	559,95	22896C	172,68	860VG810010	67,69
		100*	500	420006	599,95	23270500	172,68	860VG810009	93,67

* case machining needed/necessaria lavorazione basamento - *** case machining needed/necessaria lavorazione basamento solo per anno 2005



ENGINE VALVES
Valvole Motore

6





Modello Model	Anni Years	Tipo Type	Dimensioni Dimensions	Codice Originale OE Code	Codice Vertex Vertex Code	€
HONDA						
VALVOLE IN TITANIO - TITANIUM VALVES						
CRF150R	2007-09	SCARICO - EXHAUST	80,10x22,50x4,47	14721-KSE-670	8400023-1	125,50
CRF150R	2007-09	ASPIRAZIONE-INTAKE	78.00x26.00x4,49	14711-KSE-670	8400023-2	125,50
CRF250R	2004-07	SCARICO - EXHAUST	82.10 x 26.00 x 4.95	14721-KRN-670	8400001-4	139,13
CRF250R	2008-09	SCARICO - EXHAUST		14721-KRN-A10	8400001-6	139,13
CRF250R	2004-09	ASPIRAZIONE-INTAKE	83.35 x 31.00 x 4.95	14711-KRN-670	8400001-2	144,38
CRF250R	2010-11	ASPIRAZIONE-INTAKE		14711-KRN-A40	8400032-2	144,38
CRF250X	2004-11	SCARICO - EXHAUST	82.10 x 26.00 x 4.95	14721-KRN-670	8400001-4	139,13
CRF250X	2004-11	ASPIRAZIONE-INTAKE	83.35 x 31.00 x 4.95	14711-KRN-670	8400001-2	144,38
CRF450R	2002-06	SCARICO - EXHAUST	84.25 x 31.00 x 4.95	14721-MEB-670	8400002-4	139,13
CRF450R	2002-08	ASPIRAZIONE - INTAKE	84.60 x 36.00 x 5.48	14711-MEB-670	8400002-2	139,13
CRF450R	2009-11	ASPIRAZIONE - INTAKE		14711-MEN-A30	8400027-2	139,13
CRF450X	2005-11	ASPIRAZIONE - INTAKE	84.60 x 35.00 x 5.48	14711-MEY-670	8400028-2	139,13
VALVOLE IN ACCIAIO - STEEL VALVES						
CRF150R	2007-09	SCARICO - EXHAUST	80,10x22,50x4,47	14721-KSE-670	8400020-1	22,80
CRF150R	2007-09	ASPIRAZIONE-INTAKE	78.00x26.00x4,49	14711-KSE-670	8400020-2	22,80
CRF250R	2004-07	SCARICO - EXHAUST	82.10 x 26.00 x 4.95	14721-KRN-670	8400001-1	23,10
CRF250R	2008-09	SCARICO - EXHAUST		14721-KRN-A10	8400001-5	23,10
CRF250R	2010-11	SCARICO - EXHAUST		14721-KRN-A40	8400032-1	25,10
CRF250X	2004-11	SCARICO - EXHAUST	82.10 x 26.00 x 4.95	14721-KRN-670	8400001-1	23,10
XR400	1996-04	SCARICO - EXHAUST		14721-KCY-670	8400003-1	18,38
XR400	1996-04	ASPIRAZIONE-INTAKE		14711-KCY-670	8400003-2	17,70
TRX400EX	1999-08	SCARICO - EXHAUST		14721-KCY-670	8400003-1	18,38
TRX400EX	1999-08	ASPIRAZIONE-INTAKE		14711-KCY-670	8400003-2	17,70
CRF450R	2002-06	SCARICO - EXHAUST	84.25 x 31.00 x 4.95	14721-MEB-670	8400002-1	23,10
CRF450R	2007-08	SCARICO - EXHAUST	84.25 x 30.00 x 4.95	14721-MEN-A00	8400002-5	26,25
CRF450R	2009-11	SCARICO - EXHAUST		14721-MEN-A30	8400027-1	26,25
XR600R	1993-00	SCARICO - EXHAUST		14721-MG3-000	8400004-1	26,25
XR600R	1993-00	ASPIRAZIONE-INTAKE		14711-MG3-000	8400004-2	16,70
HUSQVARNA						
VALVOLE IN TITANIO - TITANIUM VALVES						
TC/TE450/510	2005-06	SCARICO-EXHAUST	90.55x28.53x4.97	8000 A4161	8400015-1	159,21
TC/TE450/510	2005-06	ASPIRAZIONE - INTAKE	100.5 x 33,00 x 5,48	8000 A4631	8400015-2	159,21
SMR-400	2005-06	SCARICO-EXHAUST	90.55x28.53x4.97	8000 A4161	8400015-1	159,21
SMR-400	2005-06	ASPIRAZIONE - INTAKE	100.5 x 33,00 x 5,48	8000 A4631	8400015-2	159,21
KAWASAKI						
VALVOLE IN TITANIO - TITANIUM VALVES						
KX250F	2004-11	SCARICO-EXHAUST	79.10 x 25.00 x 4.46	12005-0002	8400011-1	127,18
KX250F	2004-08	ASPIRAZIONE-INTAKE	78.98 x 31.00 x 4.48	12004-0002	8400011-2	127,18
KX250F	2009-11	ASPIRAZIONE-INTAKE	78.20 x 31.00 x 4.47	12004-0033	8400030-2	127,18
KX450F	2006-08	SCARICO-EXHAUST	82.00 x 30.96 x 5.46	12005-0036	8400019-1	144,38
KX450F	2006-08	ASPIRAZIONE-INTAKE	83.30 x 36.00 x 5.47	12004-0018	8400019-2	144,38
KX450F	2009-11	SCARICO-EXHAUST	76.95 x 31.00 x 5.45	12005-0049	8400031-1	144,38



Modello Model	Anni Years	Tipo Type	Dimensioni Dimensions	Codice Originale OE Code	Codice Vertex Vertex Code	€
KAWASAKI						
VALVOLE IN TITANIO - TITANIUM VALVES						
KX450F	2009-11	ASPIRAZIONE-INTAKE	78.20 x 36.00 x 5.47	12004-0034	8400031-2	144,38
KFX450F	2008-10	SCARICO-EXHAUST	82.00 x 30.96 x 5.46	12005-0036	8400019-1	144,38
VALVOLE IN ACCIAIO - STEEL VALVES						
KXF 400	2003-06	SCARICO-EXHAUST		12005-S004	8400009-1	17,06
KXF 400	2003-06	ASPIRAZIONE-INTAKE		12004-S004	8400009-2	13,26
KTM						
VALVOLE IN TITANIO - TITANIUM VALVES						
250 SX-F	2006-11	SCARICO - EXHAUST	92.90 x 26.60 x 4.98	770.36.031.000	8400012-1	139,13
250 SX-F	2006-11	ASPIRAZIONE - INTAKE	99.40 x 30.90 x 4.98	770.36.030.000	8400012-2	139,13
250 EXC-F	2007-11	SCARICO - EXHAUST	92.90 x 26.60 x 4.98	770.36.031.000	8400012-1	139,13
250 EXC-F	2007-11	ASPIRAZIONE - INTAKE	99.40 x 30.90 x 4.98	770.36.030.000	8400012-2	139,13
450 SX-F	2003-06	SCARICO - EXHAUST	97.00 x 30.00 x 5.90	594.36.031.000	8400013-1	144,38
450 SX-F	2003-06	ASPIRAZIONE - INTAKE	97.00 x 35.00 x 5.90	594.36.030.000	8400013-2	144,38
450 SM-R	2004-07	SCARICO - EXHAUST	97.00 x 30.00 x 5.90	594.36.031.000	8400013-1	144,38
450 SM-R	2004-07	ASPIRAZIONE - INTAKE	97.00 x 35.00 x 5.90	594.36.030.000	8400013-2	144,38
450 SM-R	2008-10	SCARICO - EXHAUST		773.36.031.200	8400025-1	144,38
450 SM-R	2008-10	ASPIRAZIONE - INTAKE		773.36.030.200	8400025-2	144,38
450 SX-F	2007-11	SCARICO - EXHAUST		773.36.031.200	8400025-1	144,38
450 SX-F	2007-11	ASPIRAZIONE - INTAKE		773.36.030.200	8400025-2	144,38
450 SX ATV	2009-11	SCARICO - EXHAUST		773.36.031.200	8400025-1	144,38
450 SX ATV	2009-11	ASPIRAZIONE - INTAKE		773.36.030.200	8400025-2	144,38
505 SX-F	2007-08	SCARICO - EXHAUST		773.36.031.200	8400025-1	144,38
505 SX-F	2007-08	ASPIRAZIONE - INTAKE		773.36.030.200	8400025-2	144,38
505 SX ATV	2009-10	SCARICO - EXHAUST		773.36.031.200	8400025-1	144,38
505 SX ATV	2009-10	ASPIRAZIONE - INTAKE		773.36.030.200	8400025-2	144,38
SM-R 525	2004-07	SCARICO - EXHAUST	97.00 x 30.00 x 5.90	594.36.031.000	8400013-1	144,38
SM-R 525	2004-07	ASPIRAZIONE - INTAKE	97.00 x 35.00 x 5.90	594.36.030.000	8400013-2	144,38
SM-R 560	2004-07	SCARICO - EXHAUST	97.00 x 30.00 x 5.90	594.36.031.000	8400013-1	144,38
SM-R 560	2004-07	ASPIRAZIONE - INTAKE	97.00 x 35.00 x 5.90	594.36.030.000	8400013-2	144,38
SUZUKI						
VALVOLE IN TITANIO - TITANIUM VALVES						
RMZ250	2004-06	SCARICO - EXHAUST	79.10 x 25.00 x 4.46	12005-0002	8400011-1	127,18
RMZ250	2004-06	ASPIRAZIONE - INTAKE	78.98 x 31.00 x 4.48	12004-0002	8400011-2	127,18
RMZ250	2007-11	SCARICO - EXHAUST	80.60x 26.00 x 4.45	12912-10H00	8400021-1	127,18
RMZ250	2007-09	ASPIRAZIONE - INTAKE	80.35 x 32.00 x 4.47	12911-10H00	8400021-2	127,18
RMZ250	2010-11	ASPIRAZIONE - INTAKE		12911-49H00	8400034-2	127,18
RMZ450	2005-06	SCARICO - EXHAUST	81.30 x 29.00 x 4.95	12912-35G00	8400010-1	144,38
RMZ450	2005-06	ASPIRAZIONE - INTAKE	82.40 x 36.00 x 4.97	12911-35GU0	8400010-2	157,50
RMZ450	2007	SCARICO - EXHAUST	81.30 x 29.00 x 5.45	12912-35G20	8400022-1	144,38
RMZ450	2007	ASPIRAZIONE - INTAKE	82.40 x 36.00 x 5.47	12911-35G20	8400022-2	144,38
RMZ450	2008-11	SCARICO - EXHAUST		12912-28H00	8400029-1	144,38
RMZ450	2008-11	ASPIRAZIONE - INTAKE		12911-28H00	8400029-2	144,38



Modello Model	Anni Years	Tipo Type	Dimensioni Dimensions	Codice Originale OE Code	Codice Vertex Vertex Code	€
SUZUKI						
VALVOLE IN TITANIO - TITANIUM VALVES						
LT-R450	2006-10	SCARICO - EXHAUST		12912-45G10	8400024-1	144,38
LT-R450	2006-11	ASPIRAZIONE - INTAKE		12911-45G00	8400024-2	144,38
VALVOLE IN ACCIAIO - STEEL VALVES						
DR-Z400	2000-09	SCARICO-EXHAUST		12912-29F00	8400009-1	17,06
DR-Z400	2000-09	ASPIRAZIONE-INTAKE		12911-29F00	8400009-2	13,26
LT-Z400	2003-09	SCARICO-EXHAUST		12912-29F00	8400009-1	17,06
LT-Z400	2003-09	ASPIRAZIONE-INTAKE		12911-29F00	8400009-2	13,26

YAMAHA						
VALVOLE IN TITANIO - TITANIUM VALVES						
YZ250F	2001-11	SCARICO - EXHAUST	77.85 x 24.55 x 4.47	5NL-12121-10	8400005-1	157,50
YZ250F	2001-11	ASPIRAZIONE I - INTAKE I	78.55 x 23.00 x 3.98	5NL-12111-10	8400005-2	139,13
YZ250F	2001-11	ASPIRAZIONE II - INTAKE II	80.05 x 23.00 x 3.98	5NL-12112-10	8400005-3	139,13
WR250F	2001-11	SCARICO - EXHAUST	77.85 x 24.55 x 4.47	5NL-12121-10	8400005-1	157,50
WR250F	2001-11	ASPIRAZIONE I - INTAKE I	78.55 x 23.00 x 3.98	5NL-12111-10	8400005-2	139,13
WR250F	2001-11	ASPIRAZIONE II - INTAKE II	80.05 x 23.00 x 3.98	5NL-12112-10	8400005-3	139,13
YZ426F	2001-02	SCARICO - EXHAUST	82.00 x 28.00 x 4.97	5JG-12121-00	8400007-1	151,07
WR426F						
YZ426F	2001-02	ASPIRAZIONE I - INTAKE I	83.25 x 27.00 x 4.48	5JG-12111-00	8400007-2	151,07
WR426F						
YZ426F	2001-02	ASPIRAZIONE II - INTAKE II	84.35 x 27.00 x 4.48	5JG-12112-00	8400007-3	151,07
WR426F						
YZ450F	2003-09 2003-11	SCARICO - EXHAUST	75.08 x 28.00 x 4.96	5TA-12121-00	8400008-1	159,21
WR450F						
YZ450F	2003-09 2003-11	ASPIRAZIONE I - INTAKE I	76.30 x 27.00 x 4.48	5TA-12111-00	8400008-2	159,21
WR450F						
YZ450F	2003-09 2003-11	ASPIRAZIONE II - INTAKE II	77.20 x 27.00 x 4.48	5TA-12112-00	8400008-3	159,21
WR450F						
YZ450F	2010-11	ASPIRAZIONE-INTAKE		33D-12111-00	8400033-2	159,21
YZ450F	2010-11	SCARICO-EXHAUST		33D-12121-00	8400033-1	159,21
YFZ450	2004-11	SCARICO - EXHAUST	75.08 x 28.00 x 4.96	5TA-12121-00	8400008-1	159,21
YFZ450	2004-11	ASPIRAZIONE I - INTAKE I	76.30 x 27.00 x 4.48	5TA-12111-00	8400008-2	159,21
YFZ450	2004-11	ASPIRAZIONE II - INTAKE II	76.30 x 27.00 x 4.48	5TA-12112-00	8400008-3	159,21
VALVOLE IN ACCIAIO - STEEL VALVES						
YZ400R	1998-99	SCARICO - EXHAUST		5BE-12121-10	8400006-1	21,66
YZ400R	1998-99	ASPIRAZIONE I - INTAKE I		5BE-12111-10	8400006-2	17,80
YZ400R	1998-99	ASPIRAZIONE II - INTAKE II		5BE-12112-10	8400006-3	17,80
WR400F	1998-00	SCARICO - EXHAUST		5BE-12121-10	8400006-1	21,66
WR400F	1998-00	ASPIRAZIONE I - INTAKE I		5BE-12111-10	8400006-2	17,80
WR400F	1998-00	ASPIRAZIONE II - INTAKE II		5BE-12112-10	8400006-3	17,80
YZ426F	2000	SCARICO - EXHAUST		5BE-12121-10	8400006-1	21,66
YZ426F	2000	ASPIRAZIONE I - INTAKE I		5BE-12111-10	8400006-2	17,80
YZ426F	2000	ASPIRAZIONE II - INTAKE II		5BE-12112-10	8400006-3	17,80

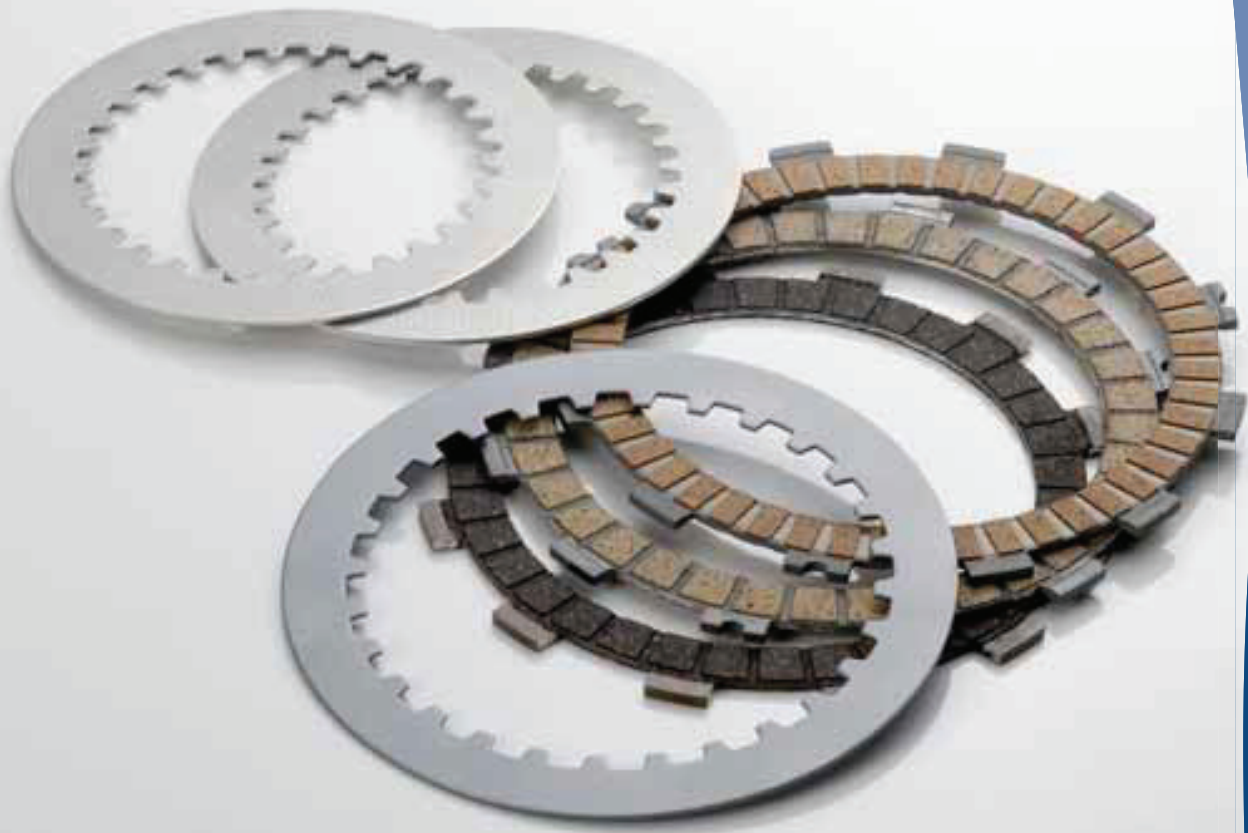

CLUTCH PLATES
Dischi Frizione

7





Codice Code	Modello Model	Anni Years	Tipo Type	Pezzi n° Pieces #	Prezzo Kit Kit Price
					€
GAS GAS					
8220005-8	125	2000-11	Frizione / Friction	8	81,98
8222001-4			Alluminio / Aluminum	4	29,61
8221002-3			Acciaio / Steel	3	22,61
HONDA					
8220001-4	CR80	1980-83	Frizione / Friction	4	39,83
8221001-3			Acciaio / Steel	3	17,08
8220001-5	CR80	1984-02	Frizione / Friction	5	49,79
8221001-4			Acciaio / Steel	4	22,77
8220001-3	XR80R	1979-03	Frizione / Friction	3	29,88
8220002-5	CR80	2005	Frizione / Friction	5	45,54
8221001-4			Acciaio / Steel	4	22,77
8220001-5	CR85	2003-04	Frizione / Friction	5	49,79
8221001-4			Acciaio / Steel	4	22,77
8220002-5	CR85	2005-07	Frizione / Friction	5	45,54
8221001-4			Acciaio / Steel	4	22,77
8220001-4	XL-XR100	1987-03	Frizione / Friction	4	39,83
8220004-6	CR125	1981	Frizione / Friction	6	85,39
8220003-7	CR125	1982	Frizione / Friction	7	59,78
8220004-6	CR125	1983-84	Frizione / Friction	6	85,39
8222001-5	CR125	1983-85	Alluminio / Aluminum	5	37,01
8221002-5			Acciaio / Steel	5	37,68
8220005-6	CR125	1985	Frizione / Friction	6	61,48
8220005-7	CR125	1986-99	Frizione / Friction	7	71,73
8222001-6			Alluminio / Aluminum	6	44,41
8221002-6			Acciaio / Steel	6	45,21
8220005-8	CR125	2000-07	Frizione / Friction	8	81,98
8221002-7			Acciaio / Steel	7	52,75
8220001-4	ATC125M	1981-87	Frizione / Friction	4	39,83
8220001-4	TRX125	1987-88	Frizione / Friction	4	39,83
8220002-6	CRF150R	2007-09	Frizione / Friction	6	54,65
8221022-5			Acciaio / Steel	5	40,58
8220001-4	ATC185-200	1980-86	Frizione / Friction	4	39,83
8220001-5	XL185S	1979-83	Frizione / Friction	5	49,79
8220001-5	XL185	1979	Frizione / Friction	5	49,79
8220001-4	ATC200X	1983-87	Frizione / Friction	4	39,83
8220001-4	TRX200	1984	Frizione / Friction	4	39,83
8220001-5	TRX200D	1986-87	Frizione / Friction	5	49,79
8220001-5	XL200	1983-84	Frizione / Friction	5	49,79
8220001-5	XR200	1980-84	Frizione / Friction	5	49,79
8220001-5	XR200R	1981-83	Frizione / Friction	5	49,79
8220001-5	XR200R	1986-04	Frizione / Friction	5	49,79
8220004-7	ATC250R	1985-86	Frizione / Friction	7	99,62
8220004-7	TRX250R	1985-89	Frizione / Friction	7	99,62
8220004-6	TRX250X	1987-88	Frizione / Friction	6	85,39
8220004-6			Frizione / Friction	6	85,39
8220001-5	TRX250	1997-02	Frizione / Friction	5	49,79
8220007-7	CR250	1986-89	Frizione / Friction	7	99,62
8222002-6			Alluminio / Aluminum	6	44,41
8221003-2			Acciaio / Steel	2	16,23
8220007-8	CR250	1990-93	Frizione / Friction	8	113,85
8222002-7			Alluminio / Aluminum	7	51,81
8221003-2	CR250	1994-07	Acciaio / Steel	2	16,23
8220007-8			Frizione / Friction	8	113,85
8222002-5	CR250	1994-07	Alluminio / Aluminum	5	37,01
8221003-2			Acciaio / Steel	2	16,23



Codice Code	Modello Model	Anni Years	Tipo Type	Pezzi n° Pieces #	Prezzo Kit Kit Price
					€
HONDA					
8220008-8	CRF250R	2004-11	Frizione / Friction	8	81,98
8221004-7			Acciaio / Steel	7	56,81
8220008-8	CRF250X	2004-11	Frizione / Friction	8	81,98
8221004-7			Acciaio / Steel	7	56,81
8220004-6	XL250L	1991-96	Frizione / Friction	6	85,39
8220004-5	XR250R	1984-85	Frizione / Friction	5	71,16
8220004-6	XR250R	1986-95	Frizione / Friction	6	85,39
8220010-6	XR250R	1996-04	Frizione / Friction	6	64,90
8220012-6	TRX300FW	1998-00	Frizione / Friction	6	57,20
8220004-6	TRX300EX	1993-02	Frizione / Friction	6	85,39
8220004-6	XR350R	1983-85	Frizione / Friction	6	85,39
8220012-6	TRX400FW	1995-02	Frizione / Friction	6	57,20
8220010-7	TRX400EX	1999-08	Frizione / Friction	7	75,72
-			Acciaio / Steel	6	-
8220009-8	CRF450R	2002-11	Frizione / Friction	8	85,29
8221003-7		2002-11	Acciaio / Steel	7	56,81
8220009-8	CRF450X	2005-11	Frizione / Friction	8	85,29
8221003-7			Acciaio / Steel	7	56,81
8220009-7	TRX450R	2004-09	Frizione / Friction	7	74,63
8220061-1			Frizione / Friction	1	11,25
8221003-7			Acciaio / Steel	7	56,81
8220010-7	XR400R	1996-04	Frizione / Friction	7	75,72
8221004-6			Acciaio / Steel	6	48,69
8220006-7	CR500	1984-89	Frizione / Friction	7	87,67
8222002-6			Alluminio / Aluminum	6	44,41
8220006-8	CR500	1990	Frizione / Friction	8	100,19
8222002-7			Alluminio / Aluminum	7	51,81
8221005-7			Acciaio / Steel	7	53,76
8220007-8	CR500	1991-03	Frizione / Friction	8	113,85
8222002-5			Alluminio / Aluminum	5	37,01
8221003-2			Acciaio / Steel	2	16,23
8220012-6	XL500S	1979-81	Frizione / Friction	6	57,20
8220013-1	XL500R	1982	Frizione / Friction	1	10,25
8220012-7	XR500	1979-80	Frizione / Friction	7	66,73
8220012-7	XR500R	1981-82	Frizione / Friction	7	66,73
8220011-7	XR500	1983-84	Frizione / Friction	7	98,54
8220011-7	XL600	1983-87	Frizione / Friction	7	98,54
8220011-7	XR600R	1985-00	Frizione / Friction	7	98,54
8221005-6			Acciaio / Steel	6	46,08
8220007-7	XR650L	1993-02	Frizione / Friction	7	99,62
KAWASAKI					
8220014-5	KX60	1983-04	Frizione / Friction	5	47,67
8221006-4			Acciaio / Steel	4	26,17
8220014-5	KX65	2000-11	Frizione / Friction	5	47,67
8221006-4			Acciaio / Steel	4	26,17
8220014-5	KX80	1981-84	Frizione / Friction	5	47,67
8221006-4			Acciaio / Steel	4	26,17
8220014-6	KX80	1985-87	Frizione / Friction	6	57,20
8221006-5			Acciaio / Steel	5	32,71
8220015-7	KX80	1988	Frizione / Friction	7	67,75
8221006-6	KX80	1988-90	Acciaio / Steel	6	39,25
8220015-6	KX80	1989-97	Frizione / Friction	6	58,07
8220016-1			Frizione / Friction	1	9,83
8221006-5			Acciaio / Steel	5	32,71



Codice Code	Modello Model	Anni Years	Tipo Type	Pezzi n° Pieces #	Prezzo Kit Kit Price
					€
KAWASAKI					
8220016-6	KX80	1998-00	Frizione / Friction	6	58,94
8221007-5			Acciaio / Steel	5	33,44
8220014-5	KDX80	1982-88	Frizione / Friction	5	47,67
8221006-4			Acciaio / Steel	4	26,17
8220016-6	KX85	2001-11	Frizione / Friction	6	58,94
8221007-5			Acciaio / Steel	5	33,44
8220015-6	KX100	1995-97	Frizione / Friction	6	58,07
8220016-1			Frizione / Friction	1	9,83
8220016-6	KX100	1998-11	Frizione / Friction	6	58,94
8221007-5			Acciaio / Steel	5	33,44
8220017-7	KX125	1985-87	Frizione / Friction	7	71,73
8222003-6			Alluminio / Aluminum	6	53,78
8221009-6			Acciaio / Steel	6	40,12
8220018-8	KX125	1988-93	Frizione / Friction	8	94,48
8222003-6	KX125	1989	Alluminio / Aluminum	6	53,78
8222003-7	KX125	1990-91	Alluminio / Aluminum	7	62,75
8220019-1	KX125	1992	Alluminio / Aluminum	1	11,39
8220020-7	KX125	1994-96	Frizione / Friction	7	102,59
8221008-6			Acciaio / Steel	6	40,12
8220020-5	KX125	1997-08	Frizione / Friction	5	73,28
8220021-2			Frizione / Friction	2	18,49
8221008-6			Acciaio / Steel	6	40,12
8220017-7	KDX200	1986-88	Frizione / Friction	7	71,73
8221009-6		1986-87	Acciaio / Steel	6	40,12
8220018-7	KDX200	1989-94	Frizione / Friction	7	82,67
8220017-1			Frizione / Friction	1	10,25
8220019-8	KDX200	1995-06	Frizione / Friction	8	91,08
8221010-7			Acciaio / Steel	7	56,73
8220019-8	KDX220R	1997-05	Frizione / Friction	8	91,08
8221010-7			Acciaio / Steel	7	56,73
8220018-7	KX250	1978-81	Frizione / Friction	7	82,67
8220022-7	KX250	1982-83	Frizione / Friction	7	71,73
8221012-6	KX250	1982-84	Acciaio / Steel	6	47,82
8221012-7	KX250	1985-86	Acciaio / Steel	7	55,79
8220023-8	KX250	1987-91	Frizione / Friction	8	125,20
8222004-7	KX250	1987	Alluminio / Aluminum	7	59,78
8221012-7	KX250	1991	Acciaio / Steel	7	55,79
8220024-8	KX250	1992-02	Frizione / Friction	8	121,80
8221013-7			Acciaio / Steel	7	59,78
8220024-8	KX250	2003-08	Frizione / Friction	8	121,80
8221013-7			Acciaio / Steel	7	59,78
8220025-6	KXF250	2004	Frizione / Friction	6	74,28
8220028-2			Frizione / Friction	2	25,61
8221008-7			Acciaio / Steel	7	46,81
8220027-6	KXF250	2005	Frizione / Friction	6	76,82
8220028-2			Frizione / Friction	2	25,61
8221008-7			Acciaio / Steel	7	46,81
8220028-8	KXF250	2006-11	Frizione / Friction	8	102,43
8221008-7			Acciaio / Steel	7	46,81
8220022-6	KDX400	1979-80	Frizione / Friction	6	61,48
8220040-7	KLX400R	2003	Frizione / Friction	7	84,63
8220041-1			Frizione / Friction	1	12,09
8221014-7			Acciaio / Steel	7	36,81



Codice Code	Modello Model	Anni Years	Tipo Type	Pezzi n° Pieces #	Prezzo Kit Kit Price
					€
KAWASAKI					
8220040-7	KFX400	2005-06	Frizione / Friction	7	84,63
8220041-1			Frizione / Friction	1	12,09
8221017-8			Acciaio / Steel	8	42,07
8220022-6	KDX420	1981	Frizione / Friction	6	61,48
8220040-6	KXF450	2006-11	Frizione / Friction	6	72,54
8220009-2			Frizione / Friction	2	21,33
8221017-7			Acciaio / Steel	7	36,81
8220022-7	KX500	1983-86	Frizione / Friction	7	71,73
8221012-6	KX500	1983-84	Acciaio / Steel	6	47,82
8221012-7	KX500	1985-86	Acciaio / Steel	7	55,79
8220023-8	KX500	1987-04	Frizione / Friction	8	125,20
8222004-7	KX500	1987	Alluminio / Aluminum	7	59,78

KTM					
8220005-7	125-144-150SX-EXC	1998-11	Frizione / Friction	7	71,73
8221002-2			Acciaio / Steel	2	15,07
8222001-4			Alluminio / Aluminum	4	29,61
8220005-7	200SX-EXC	1998-11	Frizione / Friction	7	71,73
8221002-2			Acciaio / Steel	2	15,07
8222001-4			Alluminio / Aluminum	4	29,61
8220031-9	250SX-EXC	1991-11	Frizione / Friction	9	120,35
8220008-8	250SX-F	2006-11	Frizione / Friction	8	81,98
8221004-7			Acciaio / Steel	7	56,81
8220008-8	250EXC-F	2007-11	Frizione / Friction	8	81,98
8221004-7			Acciaio / Steel	7	56,81
8220031-9	300EXC-MXC	1991-11	Frizione / Friction	9	120,35

SUZUKI					
8220014-5	RM65	2003-06	Frizione / Friction	5	47,67
8221006-4			Acciaio / Steel	4	26,17
8220032-4	RM80	1977	Frizione / Friction	4	36,44
8220032-5	RM80	1978-81	Frizione / Friction	5	45,54
8220032-4	RM80	1982-83	Frizione / Friction	4	36,44
8220032-5	RM80	1984-85	Frizione / Friction	5	45,54
8220032-5	RM80	1989-01	Frizione / Friction	5	45,54
8220032-5	RM85	2002-11	Frizione / Friction	5	45,54
8220032-6	RM100	1976	Frizione / Friction	6	54,65
8220032-7	RM100	1977-78	Frizione / Friction	7	63,76
8220032-6	RM100	1979-81	Frizione / Friction	6	54,65
8220032-6	RM125	1975	Frizione / Friction	6	54,65
8220032-7	RM125	1976-78	Frizione / Friction	7	63,76
8220032-6	RM125	1979-80	Frizione / Friction	6	54,65
8220032-7	RM125	1981-83-85	Frizione / Friction	7	63,76
8220032-6	RM125	1986-87	Frizione / Friction	6	54,65
8220033-8	RM125	1992-01	Frizione / Friction	8	97,87
8221015-7			Acciaio / Steel	7	46,81
8220034-6	RM125	2002-11	Frizione / Friction	6	77,69
8220034-2			Frizione / Friction	2	25,90
8221015-7			Acciaio / Steel	7	46,81
8220036-5	RM250	1976-78	Frizione / Friction	5	68,31
8220035-5	RM250	1979-85	Frizione / Friction	5	52,01



Codice Code	Modello Model	Anni Years	Tipo Type	Pezzi n° Pieces #	Prezzo Kit Kit Price
					€
SUZUKI					
8220036-6	RM250	1986-87	Frizione / Friction	6	81,98
8220036-8	RM250	1988-91	Frizione / Friction	8	109,30
8221027-7			Acciaio / Steel	7	56,81
8220036-9	RM250	1992-93	Frizione / Friction	9	122,96
8221027-8			Acciaio / Steel	8	64,92
8220036-8	RM250	1994-95	Frizione / Friction	8	109,30
8221027-7			Acciaio / Steel	7	56,81
8220037-8	RM250	1996-02	Frizione / Friction	8	151,36
8221016-7			Acciaio / Steel	7	39,85
8222005-7			Alluminio / Aluminum	7	92,60
8220038-6	RM250	2003-05	Frizione / Friction	6	79,37
8220039-2			Frizione / Friction	2	26,46
8221016-7			Acciaio / Steel	7	39,85
8222005-7			Alluminio / Aluminum	7	92,60
8220063-8	RM250	2006-11	Frizione / Friction	8	118,41
8221016-7			Acciaio / Steel	7	39,85
8220036-8	RMX250	1989-91	Frizione / Friction	8	109,30
8220036-9	RMX250	1992-93	Frizione / Friction	9	122,96
8220036-8	RMX250	1994-98	Frizione / Friction	8	109,30
8220025-6	RMZ250	2004	Frizione / Friction	6	74,28
8220028-2			Frizione / Friction	2	25,61
8221008-7			Acciaio / Steel	7	46,81
8220027-6	RMZ250	2005-06	Frizione / Friction	6	76,82
8220028-2			Frizione / Friction	2	25,61
8221008-7			Acciaio / Steel	7	46,81
8220028-8	RMZ250	2007-11	Frizione / Friction	8	102,43
8221008-7			Acciaio / Steel	7	46,81
8220036-7	DR250	1990-95	Frizione / Friction	7	95,64
8220036-7	DR350	1990-99	Frizione / Friction	7	95,64
8220036-6	RM370	1976-77	Frizione / Friction	6	81,98
8220040-7	DRZ400	2000-07	Frizione / Friction	7	84,63
8220041-1			Frizione / Friction	1	12,09
8221017-7			Acciaio / Steel	7	36,81
8220040-7	LTZ400	2003-04	Frizione / Friction	7	84,63
8220041-1			Frizione / Friction	1	12,09
8221017-7			Acciaio / Steel	7	36,81
8220042-6	RMZ450	2005-07	Frizione / Friction	6	67,45
8220039-2			Frizione / Friction	2	26,46
8221018-6			Acciaio / Steel	6	29,07
8221019-1			Acciaio / Steel	1	4,85
8220042-3	RMZ450	2008-11	Frizione / Friction	3	33,73
8220039-5			Frizione / Friction	5	66,14
8221018-6			Acciaio / Steel	6	29,07
8221019-1			Acciaio / Steel	1	4,85
8220035-8	RM465	1981-82	Frizione / Friction	8	83,22
8220035-8	RM500	1983-84	Frizione / Friction	8	83,22
8220035-8	DR600		Frizione / Friction	8	83,22
YAMAHA					
8220043-5	YZ80	1983-92	Frizione / Friction	5	47,67
8220044-6	YZ80	1993-94	Frizione / Friction	6	63,22
8220044-5	YZ80	1995-01	Frizione / Friction	5	52,69
8220043-2			Frizione / Friction	2	19,07



Codice Code	Modello Model	Anni Years	Tipo Type	Pezzi n° Pieces #	Prezzo Kit Kit Price
					€
YAMAHA					
8220044-5	YZ85	2002-11	Frizione / Friction	5	52,69
8220043-2			Frizione / Friction	2	19,07
8220045-6	YZ125	1983-87	Frizione / Friction	6	88,81
8220045-7	YZ125	1988	Frizione / Friction	7	103,61
8220045-5	YZ125	1989-90	Frizione / Friction	5	74,01
8220045-2			Frizione / Friction	2	29,61
8220046-7	YZ125	1991-92	Frizione / Friction	7	111,58
8221020-6			Acciaio / Steel	6	29,07
8220046-8	YZ125	1993-97	Frizione / Friction	8	127,52
8221020-7			Acciaio / Steel	7	33,91
8220047-8	YZ125	1998-99	Frizione / Friction	8	80,82
8221020-7			Acciaio / Steel	7	33,91
8220047-6	YZ125	2000-04	Frizione / Friction	6	60,61
8220046-2			Frizione / Friction	2	31,88
8221020-7	YZ125	2005-11	Acciaio / Steel	7	33,91
8220046-8			Frizione / Friction	8	127,52
8221020-7	BLASTER200	1988-06	Acciaio / Steel	7	33,91
8220043-6			Frizione / Friction	6	57,20
8220048-1	BLASTER200	1988-06	Frizione / Friction	1	9,54
8221025-6			Acciaio / Steel	6	29,07
8220049-7	YZ250	1982-87	Frizione / Friction	7	101,43
8220050-7	YZ250	1988-90	Frizione / Friction	7	93,61
8221021-6			Acciaio / Steel	6	34,16
8220051-7	YZ250	1991-92	Frizione / Friction	7	111,58
8220051-8	YZ250	1993-11	Frizione / Friction	8	127,52
8221021-7			Acciaio / Steel	7	39,85
8220047-7	YZ250F	2001-07	Frizione / Friction	7	70,72
8220046-2			WR250F	2001-11	Frizione / Friction
8221023-8	YZ250F	2008-11	Acciaio / Steel	8	38,76
8220060-9			Frizione / Friction	9	101,17
8221023-8	WR250	1989-90	Acciaio / Steel	8	38,76
8220050-7			Frizione / Friction	7	93,61
8220051-7	WR250	1991-93	Frizione / Friction	7	111,58
8220051-8	WR250	1994-97	Frizione / Friction	8	127,52
8220053-7	RD350LC	1986-92	Frizione / Friction	7	73,76
8220053-7	BANSHEE350	1987-06	Frizione / Friction	7	73,76
8221026-6			Acciaio / Steel	6	34,16
8220053-6	RAPTOR350	2005-11	Frizione / Friction	6	63,22
8220062-1			Frizione / Friction	1	9,53
8220053-6	WARRIOR350	1987-04	Frizione / Friction	6	63,22
8220062-1			Frizione / Friction	1	9,53
8220052-6	XT250	1980-83	Frizione / Friction	6	61,48
8220052-7	XT350	1985-98	Frizione / Friction	7	71,73
8220054-7	YZ-WR400F	1998-99	Frizione / Friction	7	76,66
8220055-1			Frizione / Friction	1	10,96
8220051-9	YZ426F	2000	Frizione / Friction	9	143,46
8221024-8			Acciaio / Steel	8	45,54
8220051-8	YZ-WR426F	2001-02	Frizione / Friction	8	127,52
8220056-1			Frizione / Friction	1	14,49
8221024-8	YZ450F	2003-06	Acciaio / Steel	8	45,54
8220057-9			Frizione / Friction	9	95,95
8221024-8	YZ450F	2003-06	Acciaio / Steel	8	45,54
8220057-9			Frizione / Friction	9	95,95



Codice Code	Modello Model	Anni Years	Tipo Type	Pezzi n° Pieces #	Prezzo Kit Kit Price
					€
YAMAHA					
8220057-8	YZ450F	2007-11	Frizione / Friction	8	85,29
8221021-7			Acciaio / Steel	7	39,85
8220057-8	WR450F	2003	Frizione / Friction	8	85,29
8220056-1			Frizione / Friction	1	14,49
8220057-9	WR450F	2004	Frizione / Friction	9	95,95
8220057-8	WR450F	2005-11	Frizione / Friction	8	85,29
8220058-7	YFZ450F	2004-06	Frizione / Friction	7	48,84
8220059-1			Frizione / Friction	1	8,25
8221021-7	YFZ450F	2007-09	Acciaio / Steel	7	39,85
8220058-7			Frizione / Friction	7	48,84
8220056-1	YFZ450F	2007-09	Frizione / Friction	1	14,49
8220049-7	YZ490	1982-90	Frizione / Friction	7	101,43
8220052-8	XT-TT500	1977-81	Frizione / Friction	8	81,98
8220049-7	WR500	1991-95	Frizione / Friction	7	101,43
8220052-6	RAPTOR660	2001-05	Frizione / Friction	6	61,48
8220053-2			Frizione / Friction	2	21,08



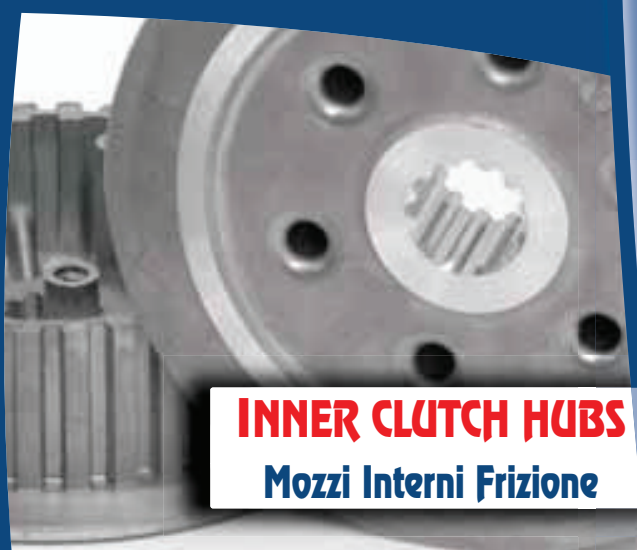

INNER CLUTCH HUBS
Mozi Interni Frizione

8





Codice Code	Tipo Type	Anni Years	€	Note Notes
HONDA				
MOTO 2 TEMPI - MOTORCYCLES 2 STROKE				
8230001	CR80	1987-96	31,45	
8230002	CR80	1997-02	27,04	
8230002	CR85	2003-07	27,04	
8230003	CR125	1986-99	40,13	
8230004	CR125	2000-07	41,69	Fino ad esaurimento scorte. Verrà sostituito da 8230022 8230022 will replace 8230004 once out of stock
8230022	CR125	2000-07	48,25	
8230005	CR250	1990-07	48,96	Fino ad esaurimento scorte. Verrà sostituito da 8230023 8230023 will replace 8230005 once out of stock
8230023	CR250	1990-07	48,96	
8230006	CR500	1986-89	47,30	
8230007	CR500	1990-01	47,30	
MOTO 4 TEMPI - MOTORCYCLES 4 STROKE				
8230021	CRF150R	2007-09	40,58	
8230004	CRF250R	2004-09	41,69	Fino ad esaurimento scorte. Verrà sostituito da 8230022 8230022 will replace 8230004 once out of stock
8230022	CRF250R CRF250X	2004-11 2007-09	41,69	
8230008	XR400R	1996-04	50,23	
8230005	CRF450R	2002-06	48,25	Fino ad esaurimento scorte. Verrà sostituito da 8230023 8230023 will replace 8230005 once out of stock
8230023	CRF450R	2002-08	48,25	
ATV 4 TEMPI - ATV 4 STROKE				
8230020	TRX400EX	1999-06	54,34	
KAWASAKI				
MOTO 2 TEMPI - MOTORCYCLES 2 STROKE				
8230011	KX60	1983-04	27,04	
8230011	KX65	2000-11	27,04	
8230012	KX80	1998-00	33,16	
8230012	KX85	2001-11	33,16	
8230012	KX100	1998-11	33,16	
8230013	KX125	1994-02	48,53	
8230014	KX125	2003-08	48,53	
8230016	KX250	1992-08	48,53	
8230018	KX500	1989-04	64,75	
MOTO 4 TEMPI - MOTORCYCLES 4 STROKE				
8230015	KX250F	2004-11	43,55	
8230019	KX450F	2006-11	54,34	
8230019	KFX450R	2008-10	54,34	
8230019	KLX450R	2008-10	54,34	
KTM				
MOTO 2 TEMPI - MOTORCYCLES 2 STROKE				
8230017	125SX-EXC	1998-05	40,13	
8230017	200SX-EXC	1998-05	40,13	
MOTO 4 TEMPI - MOTORCYCLES 4 STROKE				
8230022	SX-F250	2006-11	41,69	
8230022	EXC-F250	2007-11	41,69	
SUZUKI				
MOTO 2 TEMPI - MOTORCYCLES 2 STROKE				
8230011	RM65	2003-06	27,04	
8230009	RM125	1994-11	39,56	
MOTO 4 TEMPI - MOTORCYCLES 4 STROKE				
8230015	RMZ250	2004-06	43,55	
8230024	RMZ250	2007-11	43,55	
8230010	RMZ450	2005-11	58,92	
ATV 4 TEMPI - ATV 4 STROKE				
8230010	LT-R450	2006-07	58,92	



BEARINGS
Gabbie a Rulli





Codice Code	Tipo Type	Anni Years	Dimensioni Size (mm)	€
HONDA				
GABBIE SPINOTTO - PISTON PIN BEARINGS				
WB 107	CR80	1986-02	14x18x16	11,95
WB 107	CR85	2003-08	14x18x16	11,95
WB 109	CR125	1979-87	14x18x20	11,95
WB 110	CR125	1988-07	15x19x16,7	10,95
WB 118	CR250	1984-07	18x22x22	12,95
WB 128	CR500	1982-01	20x25x27,8	12,95
WB 118	ATC250R	1985	18x22x22	12,95
WB 118	ATC250R	1986	18x22x22	12,95
WB 118	TRX250R	1985	18x22x22	12,95
WB 118	TRX250R	1986	18x22x22	12,95
GABBIE ASSE DI ACCOPIAMENTO - BIG END BEARINGS				
B 101	CR80	1986-02	20x26x14 KU	19,25
B 101	CR85	2003-06	20x26x14 KU	19,25
B 103	CR125	1988-06	22x28x16 KU	19,25
B 105	CR250	1978-01	24x31x17 KU	19,25
B 107	CR250	2002-06	25x32x16 KU	19,25
B 107	CRF150R	2007-09	25x32x16 KU	19,25
B 130	CRF250R-X	2004-09	30x38x18 KU	19,25
TBD	CRF250R	2010	TBD	TBD
B 128	CRF450R	2002-08	34x42x20 KU	19,25
B 128	CRF450X	2005-09	34x42x20 KU	19,25
B 137	CRF450R	2009-10	33x41x19,7 KU	19,25
B 117	CR500	1982-01	26x34x20 KT	19,25
B 135	TRX250R	1987-89	24x31x17KT	19,25
B 134	TRX450R	2004-05	35x46x23,2 KU	19,25
B 128	TRX450R	2006-09	34x42x20 KU	19,25

KAWASAKI				
GABBIE SPINOTTO - PISTON PIN BEARINGS				
WB 104	KX60	1985-04	12x16x15,5	10,95
WB 104	KX65	2000-10	12x16x15,5	10,95
WB 108	KX80	1981-00	14x18x17,5	11,95
WB 104	KXF80	2003-05	12x16x15,5	10,95
WB 108	KX85	2001-10	14x18x17,5	11,95
WB 108	KX100	1998-10	14x18x17,5	11,95
WB 115	KX125	1979-93	16X21X19,5	11,95
WB 110	KX125	1994-97	15X19X17	11,95
WB 111	KX125	1998-08	15X19X20	11,95
WB 111	KMX125	-	15X19X20	11,95
WB 115	KDX200	1989-07	16X21X19,5	11,95
WB 115	KDX220	1997-07	16X21X19,5	11,95
WB 119	KDX250	1991-94	18X22X23,6	12,95
WB 119	KX250	1978-08	18X22X23,6	12,95
WB 122	KX500	1985-04	19X24X24,8	12,95
WB 132	ULTRA 130 D.I.	2001-04	22X27X24,8	13,95
WB 114	JS 440/550	1982-95	16X20X22,5	11,95
WB 119	JS 650	1986-96	18X22X23,6	12,95
WB 127	JS 750	1992-96	20X25X25	12,95
WB 132	JS 750 ZXI	1995-02	22X27X24,8	13,95
WB 132	800 SX-R	2003-07	22X27X24,8	13,95
WB 127	900 ZXI-STX-STX	1995-07	20X25X25	12,95
WB 132	1100 ZXI-STX	1996-03	22X27X24,8	13,95



Codice Code	Tipo Type	Anni Years	Dimensioni Size (mm)	€
KAWASAKI				
GABBIE ASSE DI ACCOPPIAMENTO - BIG END BEARINGS				
B101	KX60	1985-04	20X26X14 KU	19,25
B101	KX65	2000-10	20X26X14 KU	19,25
B102	KX80	1982-97	22X28X14 KU	19,25
B102	KX80	1998-02	22X28X14 KU	19,25
B102	KX85	2001-10	22X28X14 KU	19,25
B102	KX100	1995-10	22X28X14 KU	19,25
B104	KX125	1978-87	22X29X17 KU	19,25
B104	KX125	1988-91	22X29X17 KU	19,25
B104	KX125	1992-08	22X29X17 KU	19,25
B104	KX200	1988-07	22X29X17 KU	19,25
B104	KDX200	1988-07	22X29X17 KU	19,25
B104	KDX220R	1988-07	22X29X17 KU	19,25
B104	KX250	1978-08	24X32X20 KU	19,25
B130	KX250F	2004-10	30X38X18 KU	19,25
B104	KDX250	1980-94	24X32X20 KU	19,25
B129	KLX400R	2003	35X43X22 KU	19,25
B129	KFX400	2003-07	35X43X22 KU	19,25
B128	KX450F	2007-08	34x42x20KU	19,25
B111	KX500	1985-2004	26x33x22 KU	19,25
B104	JS 650	1986-96	24X32X20 KU	19,25
B120	JS 750	1992-95	26X34X20 KT	19,25
B120	JS 750-ZXI	1995-02	28X36X20 KT	19,25
B120	800SX-R	2003-07	28X36X20 KT	19,25
B117	900ZXI-STX-STX	1995-07	26X34X20 KT	19,25

KTM				
GABBIE SPINOTTO - PISTON PIN BEARINGS				
WB 102	60SX	1997-99	12X15X16,3	10,95
WB 102	65SX	2000-09	12X15X16,3	10,95
WB 139	85SX	2003-09	14X18X16,7	10,95
WB 139	105SX	2003-10	14X18X16,7	10,95
WB 111	125SX-EXC	1998-10	15X19X20	11,95
WB 111	144SX	2007-08	15X19X20	11,95
WB 111	150SX	2009-10	15X19X20	11,95
WB 113	200SX-EXC	1998-10	16X20X19,5	11,95
WB 117	250SX-EXC	1990-10	18X22X19,65	12,95
WB 117	300EXC-MXC	1990-10	18X22X19,65	12,95
8006060	360EXC	1996-97	18X22X20	9,07
8006060	380EXC	1998-02	18X22X20	9,07
GABBIE ASSE DI ACCOPPIAMENTO - BIG END BEARINGS				
B 103	85SX	2003-10	22X28X16 KU	19,25
B 103	105SX	2003-10	22X28X16 KU	19,25
B 103	125SX-EXC	1998-10	22X28X16 KU	19,25
B 103	144SX	2007-08	22X28X16 KU	19,25
B 103	150SX	2009-10	22X28X16 KU	19,25
B 103	200EXC-SX	2008-10	22X28X16 KU	19,25
B 135	250SX-EXC	1990-02	24X31X17 KT	19,25
B 105	250EXC	2003-08	24X31X17 KU	19,25
B 105	250SX	2003-10	24X31X17 KU	19,25
B 129	250EXC RACING	2001-07	35X43X22 KU	19,25
B 130	250EXC/SX-F	2005-10	30x38x18 KU	19,25
B 135	300EXC-MXC	1990-03	24X31X17 KT	19,25



Codice Code	Tipo Type	Anni Years	Dimensioni Size (mm)	€
----------------	--------------	---------------	----------------------------	---

KTM

GABBIE ASSE DI ACCOPPIAMENTO - BIG END BEARINGS

B 105	300EXC-MXC	2004-10	24X31X17 KU	19,25
B 129	450EXC	2003-07	35X43X22 KU	19,25
B 129	450SX-F	2003-04	35X43X22 KU	19,25
B 129	520SX	2000-02	35X43X22 KU	19,25
B 129	525SX-EXC RACING	2003-07	35X43X22 KU	19,25
8005040	620SC	1998-01	40X50X23	49,48
8005040	625SX-SM	2002-07	40X50X23	49,48
8005040	640LC4-DUKE II	1998-07	40X50X23	49,48

SUZUKI

GABBIE SPINOTTO - PISTON PIN BEARINGS

WB 103	RM60	2003	12X16X14,8	10,95
WB 103	RM65	2003-08	12X16X14,8	10,95
WB 104	LT80	ALL-TUTTI	12X16X15,5	10,95
WB 104	RM80	1977-82	12X16X15,5	10,95
WB 107	RM80	1983-01	14X18X16	11,95
WB 107	RM85	2002-10	14X18X16	11,95
WB 109	RM125	1980-86	14X18X20	11,95
WB 111	RM125	1988-10	15X19X20	11,95
WB 120	RM250	1989-10	18X23X22	12,95
WB 120	RMX250	1987-95	18X23X22	12,95

GABBIE ASSE DI ACCOPPIAMENTO - BIG END BEARINGS

B 101	RM60-RM65	2003-07	20X26X14 KU	19,25
B 101	RM80	1990-01	20X26X14 KU	19,25
B 101	RM85	2002-09	20X26X14 KU	19,25
B 103	RM125	1982-96	22X28X16 KU	19,25
B 103	RM125	1997-08	22X28X16 KU	19,25
B 103	TS125	1989-94	22X28X16 KU	19,25
B 106	RM250	1989-08	24X32X20 KU	19,25
B 130	RMZ250	2004-09	30X38X18 KU	19,25
B 106	RMX250	1989-98	24X32X20 KU	19,25
B 128	RMZ450	2005-08	34X42X20 KU	19,25
B 129	DRZ400	2000-08	35X43X22 KU	19,25
B 129	LTZ400	2003-07	35X43X22 KU	19,25

YAMAHA

GABBIE SPINOTTO - PISTON PIN BEARINGS

WB 107	YZ80	1993-01	14X18X16	11,95
WB 107	YZ85	2002-10	14X18X16	11,95
WB 113	YZ125	1986-96	16X20X19,5	11,95
WB 112	YZ125	1997-00	15X20X17,8	11,95
WB 110	YZ125	2001-10	15X19X17	11,95
WB 115	TZR125-250		16X21X19,5	11,95
WB 113	RD-DT125		16X20X19,5	11,95
WB 114	DT175-195-IT125		16X20X22,5	11,95
WB 113	IT125		16X20X19,5	11,95
WB 116	BLASTER200	1988-07	16X21X22,5	11,95
WB 120	YZ250	1983-98	18X23X22	12,95
WB 118	YZ250	1999-10	18X22X22	12,95
WB 116	BANSHEE350	1987-07	16X21X22,5	11,95
WB 115	RD250-350		16X21X19,5	11,95
WB 116	RD350-LS YPVS		16X21X22,5	11,95
WB 134	SJ650-700-1100	1993-07	20X25X24	12,95



Codice Code	Tipo Type	Anni Years	Dimensioni Size (mm)	€
YAMAHA				
GABBIE SPINOTTO - PISTON PIN BEARINGS				
WB 134	XL700	1995-04	20X25X24	12,95
WB 134	GP760-1200	1996-04	20X25X24	12,95
WB 134	SUV1200	1999-04	20X25X24	12,95
GABBIE ASSE DI ACCOPPIAMENTO - BIG END BEARINGS				
B101	YZ80	1993-01	20X26X14 KU	19,25
B101	YZ85	2002-09	20X26X14 KU	19,25
B104	YZ125	1980-85	22X29X17 KU	19,25
B104	YZ125	1986-10	22X29X17 KU	19,25
B104	BLASTER200	1988-07	22X29X17 KU	19,25
B104	BLASTER200HP	1988-07	22X29X17 KU	19,25
B108	YZ250	1983-98	25X32X20 KU	19,25
B105	YZ250	1999-10	24X31X17 KU	19,25
B130	YZ-WR250F	2001-02	30X38X18 KU	19,25
B132	YZ-WR250F	2003-10	32X40X18 KU	19,25
B104	BANSHEE350	1987-07	22X29X17 KU	19,25
B104	BANSHEE350HP	1987-07	22X29X17 KU	19,25
B128	YZ-WR400F	1998-99	34X42X20 KU	19,25
B128	YZ-WR426F	2000-02	34X42X20 KU	19,25
B128	YZ-WR450F	2003-09	34X42X20 KU	19,25
B131	RAPTOR660	2001-07	37X45X22 KU	19,25
B131	GRIZZLY660	2004-07	37X45X22 KU	19,25
B108	SJ650-700-1100	1993-05	25X32X20 KU	19,25
B108	XL700	1995-04	25X32X20 KU	19,25
B112	GP760-1200	1996-04	27X34X21 KU	19,25
B112	GP-XL-XLT800-1200R	1998-05	27X34X21 KU	19,25
B108	SUV1200	1999-04	25X32X20 KU	19,25
B112	XLT1200	2001-05	27X34X21 KU	19,25
B112	GP1300R	2003-05	27X34X21 KU	19,25



I kit guarnizione distribuiti da **VERTEX** sono prodotti in USA con materiali tecnologicamente all'avanguardia ed hanno come obiettivo quello di migliorare le pur ottime prestazioni già fornite dai prodotti originali, sia per motori a 2 che a 4 Tempi. Questi kit sono completi delle guarnizioni per valvole, o-rings e scarico fissando un punto di riferimento per il motociclista più evoluto che solitamente vuole sempre il massimo dal proprio motore.

Queste le configurazioni disponibili:

- **VG810** è il formato **Top End Gasket Kit** composto da guarnizione testa, basamento e tutte le altre guarnizioni necessarie in caso di sostituzione del pistone completo o dei soli segmenti.
- **VG808** è il formato **Complete Engine Kit** composto da tutte le guarnizioni necessarie per revisionare l'intero motore compreso la parte trasmissione.
- **VG822** è il formato **Oil Seal Kit** che contiene tutti i paraolio necessari per revisionare il motore compreso la parte trasmissione.

***VERTEX GASKETS** are made in the USA with the highest grade gasket materials available. They are well suited to sealing the high revving two and four stroke engines in today's market. They come complete with valve seals, o-rings and crush type exhaust gaskets where applicable. These kits are the most complete and well engineered kits available on the market today!*

***VERTEX GASKETS** are in three different kit configurations to meet your particular projects needs:*

- ***VG810** Series kits are top end gasket kits which contain head, base and all the other gaskets needed for piston or ring replacement.*
- ***VG808** Series kits are complete engine kits which contain all the gaskets necessary to rebuild the entire engine and transmission.*
- ***VG822** Series kits are oil seal kits only. They contain all the oil seals to rebuild your engine and transmission.*



GASKETS SETS
Set Guarnizioni

10

VERTEX
PISTON & POWER

Modello Model	Anni Years	Kit Guarnizioni Testa Top End Kit	€	Kit Guarnizioni senza Paraolio Complete Gasket Kit no Oil Seals	€	Kit Paraolio Oil Seals Kit	€
HONDA							
MOTO - MOTORCYCLES							
2 TEMPI - 2 STROKE							
CR80R	1986-91	860VG810205	19,78	860VG808205	54,24	860VG822181	25,38
CR80R	1992-02	860VG810206	21,65	860VG808206	54,24	860VG822181	25,38
CR85R	2003-04	860VG810211	21,65	860VG808211	54,24	860VG822181	25,38
CR85R	2005-07	860VG810212	26,48	860VG808212	60,83	860VG822181	25,38
CR125R	1988-89	860VG810233	37,03	860VG808233	56,92	860VG822107	25,38
CR125R	1990-97	860VG810235	37,03	860VG808235	56,92	860VG822107	25,38
CR125R	1998-99	860VG810236	37,03	860VG808236	60,83	860VG822107	25,38
CR125R	2000	860VG810237	37,03	860VG808247	60,83	860VG822107	25,38
CR125R	2001-02	860VG810237	37,03	860VG808237	60,83	860VG822107	25,38
CR125R	2003	860VG810239	38,68	860VG808239	65,78	860VG822265	32,05
CR125R	2004	860VG810243	40,33	860VG808243	67,42	860VG822270	32,05
CR125R	2005-07	860VG810244	40,33	860VG808244	70,73	860VG822271	34,57
CR250R	1985	860VG810253	19,48	860VG808253	59,45	860VG822109	27,73
CR250R	1986	860VG810254	19,78	860VG808254	59,45	860VG822109	27,73
CR250R	1987	860VG810255	21,95	860VG808255	67,57	860VG822109	27,73
CR250R	1988	860VG810256	37,03	860VG808256	67,57	860VG822110	23,95
CR250R (.040Comp.Head)	1989-91	860VG810257	27,50	860VG808257	67,57	860VG822110	23,95
CR250R (.010Metal Head)	1989-91	860VG810260	27,50	860VG808260	67,57	860VG822110	23,95
CR250R	1992-01	860VG810259	37,03	860VG808259	70,99	860VG822111	23,95
CR250R	2002-04	860VG810261	38,68	860VG808261	70,99	860VG822177	26,48
CR250R	2005-07	860VG810264	43,62	860VG808264	77,46	860VG822268	32,05
CR500R	1985-88	860VG810272	31,79	860VG808272	70,47	860VG822182	31,14
CR500R	1989-01	860VG810273	37,03	860VG808273	74,02	860VG822110	23,95
4 TEMPI - 4 STROKE							
CRF150R	2003-05	860VG810238	61,28	860VG808238	89,22	860VG822179	19,31
CRF150R	2007-09	860VG810014	74,99	860VG808213	136,62	860VG822332	50,25
CRF150R big bore diam. 72,00	2007-09	860VG810015	89,53				
CRF250R	2004-07	860VG810262	71,16	860VG808262	137,08	860VG822248	50,25
CRF250R	2008-09	860VG810268	71,16	860VG808268	137,08	860VG822248	50,25
CRF250R	2010-11	860VG810285	71,16	860VG808285	137,08	860VG822248	50,25
CRF250X	2004-11	860VG810262	71,16	860VG808262	137,08	860VG822248	50,25
CRF250R big bore diam. 80,00	2004-09	860VG810003	84,36				
CRF250R big bore diam. 84,00	2004-09	860VG810004	84,36				
CRF250R big bore diam. 85,00	2004-09	860VG810013	89,53				
CRF250X BB 80mm	2004-11	860VG810003	84,36				
CRF250X BB 84mm	2004-11	860VG810004	84,36				
CRF250X BB 85mm	2004-11	860VG810013	89,53				
CRF450R	2002-06	860VG810267	71,16	860VG808267	143,57	860VG822178	50,25
CRF450R	2007-08	860VG810278	86,58	860VG808278	158,98	860VG822330	52,32
CRF450R	2009-11	860VG810284	86,58	860VG808284	158,98	860VG822352	49,95
CRF450X	2005-11	860VG810276	86,58	860VG808276	158,98	860VG822315	49,95
CRF450R big bore diam. 100,00	2002-08	860VG810001	93,67				
CRF450X BB 100mm	2002-11	860VG810001	93,67				
ATV							
4 TEMPI - 4 STROKE							
TRX 400 EX Fourtrax	1999-00	860VG810829	35,83	860VG808829	60,99	860VG822139	23,74
TRX 400 EX	2001-04	860VG810829	35,83	860VG808829	60,99	860VG822139	23,74
TRX 400 EX	2005-08	860VG810829	35,83	860VG808894	73,84	860VG822278	26,88
TRX 450 R	2004-05	860VG810868	77,75	860VG808868	133,79	860VG822237	43,76
TRX 450 R	2006-09	860VG810904	92,96	860VG808904	159,57	860VG822312	49,95
KAWASAKI							
MOTO - MOTORCYCLES							
2 TEMPI - 2 STROKE							
KX60	1985-03	860VG810407	19,09	860VG808407	32,86	860VG822290	17,29
KX65	2000-05	860VG810412	25,24	860VG808412	36,45	860VG822135	21,57

Modello Model	Anni Years	Kit Guarnizioni Testa Top End Kit	€	Kit Guarnizioni senza Paraolio Complete Gasket Kit no Oil Seals	€	Kit Paraolio Oil Seals Kit	€
KAWASAKI							
MOTO - MOTORCYCLES							
2 TEMPI - 2 STROKE							
KX65	2006-09	860VG810412	25,24	860VG808417	49,30	860VG822135	21,57
KX80	1991-97	860VG810405	20,26	860VG808405	41,38	860VG822291	18,98
KX80	1998-00	860VG810410	20,26	860VG808410	50,25	860VG822292	23,08
KX85	2001-06	860VG810414	21,65	860VG808414	50,25	860VG822292	23,08
KX85	2007-11	860VG810414	21,65	860VG808419	50,25	860VG822292	23,08
KX125	1990-91	860VG810423	35,60	860VG808423	54,06	860VG822298	27,50
KX125	1992-93	860VG810424	35,60	860VG808424	53,80	860VG822298	27,50
KX125	1994	860VG810428	35,60	860VG808428	53,80	860VG822101	27,50
KX125	1995-97	860VG810425	35,60	860VG808425	66,80	860VG822101	27,50
KX125	1998-00	860VG810427	35,60	860VG808427	66,80	860VG822183	27,50
KX125	2001-02	860VG810429	37,25	860VG808429	73,69	860VG822183	27,50
KX125	2003-05	860VG810430	37,25	860VG808430	70,03	860VG822183	27,50
KLX125,125L	2003-06	860VG810531	37,88	860VG808531	70,83	860VG822226	31,31
KX250	1990-91	860VG810455	39,56	860VG808455	74,64	860VG822287	27,95
KX250	1992	860VG810456	39,56	860VG808456	74,64	860VG822287	27,95
KX250	1993-96	860VG810457	39,56	860VG808478	74,64	860VG822288	30,99
KX250	1997-03	860VG810457	39,56	860VG808457	74,64	860VG822288	30,99
KX250	2004	860VG810464	39,56	860VG808464	74,64	860VG822297	28,09
KX250	2005-08	860VG810465	39,56	860VG808465	74,64	860VG822257	28,09
4 TEMPI - 4 STROKE							
KX250F	2004-05	860VG810463	56,04	860VG808463	95,27	860VG822223	52,59
KX250F big bore diam. 83,00	2004-08	860VG810005	84,36				
KX250F big bore diam. 84,00	2004-08	860VG810006	84,36				
KX250F	2006-08	860VG810463	56,04	860VG808463	95,27	860VG822316	52,59
KX250F	2009-11	860VG810481	56,04	860VG808481	95,27	860VG822316	52,59
KLX400	2003	860VG810585	48,45	860VG808585	81,42	860VG822193	29,67
KX450F	2006-08	860VG810469	77,75	860VG808469	136,65	860VG822319	30,14
KX450F	2009-11	860VG810482	77,75	860VG808482	136,65	860VG822319	30,14
KLX450R	2008-11	860VG810469	77,75	860VG808480	136,65	860VG822336	30,14
ATV							
2 TEMPI - 2 STROKE							
KXT 250 Tecate	1986-87	860VG810819	39,67	860VG808819	52,86	860VG822159	23,71
KXF250 Tecate	1987-88	860VG810820	42,11	860VG808820	62,74	860VG822282	20,77
4 TEMPI - 4 STROKE							
KFX 400	2003-06	860VG810847	50,91	860VG808847	105,26	860VG822201	29,67
KFX 450R NEW	2008-10	860VG810920	77,75	860VG808920	136,65	860VG822334	30,14

KTM							
MOTO - MOTORCYCLES							
2 TEMPI - 2 STROKE							
KTM50ADV A/C	2002-08	860VG810314	23,00	860VG808314	31,14	860VG822246	13,38
KTM50ADV A/C	1997-01	860VG810301	19,78	860VG808301	43,07	860VG822184	14,84
KTM50SX LC	2001-07	860VG810312	14,84	860VG808312	26,23	860VG822222	17,81
KTM50SX	2009-11	860VG810337	23,00	860VG808337	31,14	860VG822347	17,81
KTM65SX	1998-08	860VG810302	26,59	860VG808302	59,56	860VG822185	29,67
KTM65SX	2009-11	860VG810338	26,59	860VG808338	59,56	860VG822348	29,67
KTM85SX	2003-11	860VG810315	26,59	860VG808315	59,56	860VG822264	45,75
KTM105SX NEW	2003-11	860VG810332	26,59	860VG808332	59,56	860VG822264	45,75
KTM125SX,EXC	1991-97	860VG810303	26,59	860VG808303	59,56	860VG822186	29,67
KTM125SX,EXC	1998-01	860VG810304	26,59	860VG808304	59,56	860VG822187	29,67
KTM125SX,EXC	2002-06	860VG810309	26,59	860VG808309	59,56	860VG822187	29,67
KTM125SX,EXC	2007-11	860VG810330	38,82	860VG808330	70,73	860VG822187	29,67
KTM144SX NEW	2007-08	860VG810330	38,82	860VG808330	70,73	860VG822187	29,67
KTM150SX NEW	2009-11	860VG810330	38,82	860VG808330	70,73	860VG822187	29,67
KTM200SX,EXC	1998-02	860VG810308	26,59	860VG808308	59,56	860VG822187	29,67
KTM200SX,EXC	2003-05	860VG810319	26,59	860VG808319	59,56	860VG822187	29,67

Modello Model	Anni Years	Kit Guarnizioni Testa Top End Kit	€	Kit Guarnizioni senza Paraolio Complete Gasket Kit no Oil Seals	€	Kit Paraolio Oil Seals Kit	€
KTM							
MOTO - MOTORCYCLES							
2 TEMPI - 2 STROKE							
KTM200XC,XC-W	2006-11	860VG810319	26,59	860VG808319	59,56	860VG822187	29,67
KTM250SX,EXC	1990-99	860VG810327	26,59	860VG808327	59,56	860VG822326	32,97
KTM250SX	2000-02	860VG810300	26,59	860VG808300	59,56	860VG822190	34,28
KTM250EXC	2000-03	860VG810300	26,59	860VG808300	59,56	860VG822190	34,28
KTM250SX	2003-04	860VG810323	26,59	860VG808323	59,56	860VG822269	29,67
KTM250EXC	2004	860VG810323	26,59	860VG808323	59,56	860VG822269	29,67
KTM250EXC	2005	860VG810324	26,59	860VG808324	59,56	860VG822269	29,67
KTM250SX	2005-06	860VG810324	26,59	860VG808324	59,56	860VG822269	29,67
KTM250XC, XC-W	2006-07	860VG810324	26,59	860VG808324	59,56	860VG822269	29,67
KTM250SX-EXC	2007-11	860VG810333	40,33	860VG808333	71,94	860VG822269	29,67
KTM300SX, EXC	1990-03	860VG810306	26,59	860VG808306	59,56	860VG822192	34,28
KTM300SX, EXC	2004	860VG810325	26,59	860VG808325	59,56	860VG822269	29,67
KTM300SX, EXC	2005	860VG810326	26,59	860VG808326	59,56	860VG822269	29,67
KTM300XC, XC-W	2006-07	860VG810326	26,59	860VG808326	59,56	860VG822269	29,67
KTM300 EXC, XC, XC-W	2008-11	860VG810335	31,79	860VG808335	66,76	860VG822269	29,67
KTM360SX,EXC	1996-97	860VG810307	26,59	860VG808307	59,56	860VG822192	34,28
KTM380SX,EXC	1998-02	860VG810307	26,59	860VG808307	59,56	860VG822192	34,28
4 TEMPI - 4 STROKE							
KTM250EXC-F	2001-05	860VG810316	70,40	860VG808316	130,67	860VG822274	37,14
KTM250SX-F - 250 EXC-F	2005-11	860VG810328	77,84	860VG808328	128,60	860VG822320	37,14
KTM250SX-F big bore diam. 80,00	2006-11	860VG810011	84,36				
KTM250SX-F big bore diam. 84,00	2006-11	860VG810012	84,36				
KTM400SX,MXC,EXC	2000-02	860VG810317	89,40	860VG808317	149,65	860VG822274	37,14
KTM400EXC	2004-06	860VG810317	89,40	860VG808317	149,65	860VG822274	37,14
KTM400XC-W	2007	860VG810317	89,40	860VG808317	149,65	860VG822274	37,14
KTM400EXC big bore diam.102,00	2009	860VG810016	96,98				
KTM450EXC	2003-07	860VG810317	89,40	860VG808317	149,65	860VG822274	37,14
KTM450EXC-R big bore diam.102,00	2008-11	860VG810016	96,98				
KTM450XC	2006-07	860VG810317	89,40	860VG808317	149,65	860VG822274	37,14
KTM450SX	2003-06	860VG810318	89,40	860VG808318	149,65	860VG822274	37,14
KTM450SX-F	2007-11	860VG810331	78,15	860VG808331	106,61	860VG822333	50,25
KTM450XC-F	2008	860VG810331	78,15	860VG808331	106,61	860VG822333	50,25
KTM505 XC,SX-F,SX	2008-09	860VG810336	85,91	860VG808336	104,02	860VG822333	50,25
KTM520SX, MXC, EXC	2000-02	860VG810318	89,40	860VG808318	149,65	860VG822274	37,14
KTM525SX, MXC, EXC	2003-07	860VG810318	89,40	860VG808318	149,65	860VG822274	37,14
KTM525XC	2006-07	860VG810318	89,40	860VG808318	149,65	860VG822274	37,14
KTM530EXC-R big bore diam.102,00	2008-11	860VG810016	96,98				
ATV							
4 TEMPI - 4 STROKE							
KTM450XC	2008-09	860VG810930	86,43	860VG808930	129,38	860VG822335	37,14
KTM450SX	2009-11	860VG810931	86,43	860VG808931	104,02	860VG822342	40,89
KTM505 SX	2009-11	860VG810942	86,43	860VG808942	104,02	860VG822342	40,89
KTM525XC	2008	860VG810921	89,40	860VG808921	149,65	860VG822335	37,14
POLARIS							
ATV							
2 TEMPI - 2 STROKE							
90 Scrambler	2001-03	860VG810840	14,84	860VG808887	31,31	860VG822261	16,26
90 Sportsman	2001-04	860VG810840	14,84	860VG808887	31,31	860VG822261	16,26
90 Sportsman	2005-08	860VG810840	14,84	860VG808908	31,31	860VG822322	19,57
250 All	1985-06	860VG810806	21,03	860VG808806	25,50	860VG822140	9,74
400 All	1994-02	860VG810808	29,52	860VG808808	50,18	860VG822142	20,19
4 TEMPI - 4 STROKE							
500 Predator	2003-04	860VG810876	82,26	860VG808876	118,51	860VG822249	17,81
500 Predator	2005-07	860VG810876	82,26	860VG808907	118,51	860VG822249	17,81
500 Outlaw	2006-07	860VG810876	82,26	860VG808907	118,51	860VG822249	17,81

Modello Model	Anni Years	Kit Guarnizioni Testa Top End Kit	€	Kit Guarnizioni senza Paraolio Complete Gasket Kit no Oil Seals	€	Kit Paraolio Oil Seals Kit	€
SUZUKI							
MOTO - MOTORCYCLES							
2 TEMPI - 2 STROKE							
RM60	2003	860VG810407	19,09	860VG808407	32,86	860VG822290	17,29
RM65	2003-05	860VG810412	25,24	860VG808412	36,45	860VG822135	21,57
RM80	1990	860VG810503	15,98	860VG808503	46,62	860VG822305	25,35
RM80	1991-01	860VG810504	15,98	860VG808504	43,33	860VG822123	29,16
RM85	2002-11	860VG810505	17,98	860VG808505	46,62	860VG822176	25,24
RM125	1990	860VG810544	19,78	860VG808544	72,08	860VG822131	25,86
RM125	1991	860VG810545	19,78	860VG808545	72,08	860VG822131	25,86
RM125	1992-97	860VG810547	23,95	860VG808547	72,08	860VG822124	25,86
RM125	1998-00	860VG810548	23,95	860VG808548	72,08	860VG822125	25,86
RM125	2001-03	860VG810548	23,95	860VG808549	72,08	860VG822267	30,99
RM125	2004-10	860VG810550	25,64	860VG808550	75,75	860VG822266	30,99
RM250	1989	860VG810575	30,22	860VG808575	76,51	860VG822126	25,97
RM250	1990	860VG810576	30,22	860VG808576	76,51	860VG822126	25,97
RM250	1991	860VG810569	35,60	860VG808569	81,89	860VG822126	25,97
RM250	1992-93	860VG810577	30,22	860VG808577	76,51	860VG822126	25,97
RM250	1994-95	860VG810581	35,60	860VG808581	76,51	860VG822134	25,97
RM250	1996-98	860VG810580	35,60	860VG808580	76,51	860VG822127	30,22
RM250	1999-00	860VG810582	35,60	860VG808582	76,51	860VG822127	30,22
RM250	2001	860VG810583	35,60	860VG808583	76,51	860VG822127	30,22
RM250	2002	860VG810587	35,60	860VG808587	76,51	860VG822127	30,22
RM250	2003-05	860VG810589	42,19	860VG808589	89,92	860VG822227	35,24
RM250	2006-11	860VG810593	42,19	860VG808593	89,92	860VG822317	35,24
4 TEMPI - 4 STROKE							
RM-Z250	2004-06	860VG810463	56,04	860VG808463	95,27	860VG822223	52,59
RM-Z250	2007-09	860VG810568	60,55	860VG808568	106,09	860VG822329	42,75
RM-Z250 NEW	2010-11	860VG810567	60,55	860VG808567	106,09	860VG822355	42,75
RM-Z250 big bore diam. 83,00	2004-06	860VG810005	84,36				
RM-Z250 big bore diam. 84,00	2004-06	860VG810006	84,36				
DRZ400,E,S,ES,SM	2000-08	860VG810585	48,45	860VG808585	81,42	860VG822193	29,67
RM-Z450	2005-07	860VG810590	69,37	860VG808590	136,65	860VG822318	30,99
RM-Z450	2008-11	860VG810595	69,37	860VG808595	136,65	860VG822346	30,99
RM-Z450 big bore diam. 100,00	2005-07	860VG810002	96,98				
ATV							
4 TEMPI - 4 STROKE							
LTZ400 Z	2003-08	860VG810847	50,91	860VG808847	105,26	860VG822201	29,67
LTZ400 Z	2009	860VG810847	50,91	860VG808933	105,26	860VG822201	29,67

YAMAHA							
MOTO - MOTORCYCLES							
2 TEMPI - 2 STROKE							
YZ80	1993-01	860VG810613	18,31	860VG808613	38,09	860VG822113	25,57
YZ85	2002-11	860VG810614	19,78	860VG808614	41,38	860VG822173	21,10
YZ125	1992	860VG810634	19,78	860VG808634	46,26	860VG822116	27,76
YZ125	1993	860VG810635	19,78	860VG808635	46,26	860VG822115	27,76
YZ125	1994-97	860VG810636	19,78	860VG808636	46,26	860VG822115	27,76
YZ125	1998-00	860VG810637	19,78	860VG808637	46,26	860VG822114	27,76
YZ125	2001	860VG810637	19,78	860VG808637	46,26	860VG822172	27,76
YZ125	2002-04	860VG810639	21,57	860VG808639	52,85	860VG822172	27,76
YZ125	2005-11	860VG810641	26,23	860VG808641	55,89	860VG822252	35,35
TTR125	2001-09	860VG810640	41,17	860VG808640	67,57	860VG822240	22,38

Modello Model	Anni Years	Kit Guarnizioni Testa Top End Kit	€	Kit Guarnizioni senza Paraolio Complete Gasket Kit no Oil Seals	€	Kit Paraolio Oil Seals Kit	€
YAMAHA							
MOTO - MOTORCYCLES							
2 TEMPI - 2 STROKE							
YZ250	1990-91	860VG810663	23,00	860VG808663	48,93	860VG822117	30,04
YZ250	1992-94	860VG810664	17,98	860VG808664	48,93	860VG822117	30,04
YZ250	1995-96	860VG810665	23,95	860VG808665	48,93	860VG822117	30,04
YZ250	1997	860VG810666	29,67	860VG808666	48,93	860VG822117	30,04
YZ250	1998	860VG810666	29,67	860VG808666	48,93	860VG822118	30,04
YZ250	1999-00	860VG810668	29,67	860VG808668	48,93	860VG822122	30,04
YZ250	2001	860VG810669	31,50	860VG808669	54,24	860VG822174	33,81
YZ250	2002-11	860VG810670	29,67	860VG808670	54,43	860VG822304	28,21
4 TEMPI - 4 STROKE							
YZ250F	2001-11	860VG810671	49,45	860VG808671	90,65	860VG822175	27,22
WR250F	2001-02	860VG810671	49,45	860VG808671	90,65	860VG822175	27,22
WR250F	2003-11	860VG810671	49,45	860VG808678	90,65	860VG822175	27,22
YZ250F-WR250F big bore diam. 84,00	2001-11	860VG810008	84,36				
YZ400F	1998-99	860VG810675	56,04	860VG808675	90,65	860VG822167	27,22
WR400F	1998-99	860VG810675	56,04	860VG808675	90,65	860VG822167	27,22
WR400F	2000	860VG810676	56,04	860VG808676	90,65	860VG822167	27,22
YZ426F	2000-02	860VG810676	56,04	860VG808676	90,65	860VG822167	27,22
WR426F	2001-02	860VG810676	56,04	860VG808676	90,65	860VG822167	27,22
YZ450F	2003-05	860VG810677	56,04	860VG808677	90,65	860VG822228	33,81
YZ450F	2006-09	860VG810010	67,69	860VG808687	102,78	860VG822228	33,81
YZ450F	2010-11	860VG810689	67,69	860VG808689	102,78	860VG822228	33,81
WR450F	2003-06	860VG810677	56,04	860VG808679	93,94	860VG822228	33,81
WR450F	2007-11	860VG810010	67,69	860VG808687	102,78	860VG822228	33,81
YZ450F BB 100mm	2006-09	860VG810009	93,67				
WR450F BB 100mm	2006-11	860VG810009	93,67				
ATV							
2 TEMPI - 2 STROKE							
YFS 200 Blaster	1988-06	860VG810811	34,28	860VG808811	51,42	860VG822153	22,02
YFZ 350 Banshee	1987-06	860VG810812	43,73	860VG808812	72,19	860VG822154	31,76
4 TEMPI - 4 STROKE							
YFM 350 Warrior	1987-04	860VG810813	36,92	860VG808813	78,97	860VG822155	28,57
YFM 350 Raptor	2005-11	860VG810813	36,92	860VG808813	78,97	860VG822155	28,57
YFM 350 Wolverine	1995-05	860VG810813	36,92	860VG808861	81,20	860VG822218	30,84
YFM 350 Big Bear	1997-99	860VG810813	36,92	860VG808861	81,20	860VG822218	30,84
YFM 350 Big Bear	1987-96	860VG810898	40,21	860VG808898	93,32	860VG822279	45,67
YFM 350 Big Bear 2x4	1997-98	860VG810898	40,21	860VG808898	93,32	860VG822279	45,67
YFM 350 Bruin	2004-07	860VG810813	36,92	860VG808882	67,90	860VG822253	38,75
YFM 350 Wolverine	2006-11	860VG810813	36,92	860VG808882	67,90	860VG822253	38,75
YFZ 450	2004-09	860VG810869	60,99	860VG808869	98,82	860VG822238	33,81
YFM 660 Grizzly	2002-08	860VG810865	85,37	860VG808865	151,29	860VG822233	59,23
Rhino 660 Auto 4WD	2004-07	860VG810865	85,37	860VG808865	151,29	860VG822233	59,23
YFM 660 Raptor	2001-05	860VG810852	75,82	860VG808852	143,38	860VG822232	36,48



Modello Model	Anni Years	Codice Code	Numero Maglie # of Links	€
HONDA				
CRF250R	2004-09	8892RH2015104	104	54,86
CRF250X	2004-11	8892RH2015104	104	54,86
CRF250R	2010-11	8892RH2015106	106	54,86
CRF450R	2004-08	8892RH2015112	112	56,93
CRF450X	2004-08	8892RH2015112	112	56,93
CRF450R	2009-11	8896RH2015108	108	59,00
TRX450R ATV	2004-05	8892RH2015114	114	56,93
	2006-09	8892RH2015112	112	56,93

KAWASAKI				
KX250F	2004-11	8892RH2010114	114	51,65
KX450F	2006-07	8898XRH2010124	124	54,86
	2008-11	8898XRH2010122	122	54,86
KLX450R	2008-10	8898XRH2010124	124	54,86
KFX450R ATV	2008-09	8898XRH2010126	126	54,86
EX250E1,2	1986-87	8882RH2010124	124	51,65
EX250F1	1986-05	8882RH2010124	124	51,65
EX250G1	1988	8882RH2010124	124	51,65
EX250H1-6	1990-2006	8882RH2010124	124	51,65
EL250A1-6	87>90-94-96	8882RH2010124	124	51,65
EL250C1-6	89>96-98	8882RH2010124	124	51,65
EL250D1-5-7	90>94-96	8882RH2010124	124	51,65
EL250E1-4	91>94	8882RH2010124	124	51,65
EL250F2-6	96-97-99-01-03	8882RH2010124	124	51,65
KLE250A1-6	93-95-97-99>01	8882RH2010124	124	51,65

SUZUKI				
RMZ250K	2004-11	8892RH2010114	114	51,65
RMZ450K	2005-11	8882RH2010124	124	51,65
RMX450Z	2010	8882RH2010124	124	51,65
GSF250	(89>)	8882RH2010124	124	51,65
LTR450 ATV	2006-09	8898XRH2010126	126	54,86

YAMAHA				
YZF250F	2004-11	8892RH2010114	114	51,65
WR250F	2004-11	8892RH2010114	114	51,65
YZ450F	2004-09	8898XRH2010118	118	54,86
WR450F	2004-11	8898XRH2010118	118	54,86
YZ400F	2003>	8898XRH2010118	118	54,86
YZ450F	2010-11	8898XRH2010122	122	54,86
YFZ450 ATV	2004-09	8898XRH2010118	118	54,86



Codice pistone Piston part No.	Marca Make	Quota compressione compression height	Bombatura testa head	Diametro foro spinotto Pin diameter
CODICI PISTONI CROSS 2T / OFF ROAD 2STROKE REF. LIST				
1600	CAGIVA	30,00	3,2	16,00
1757	CAGIVA	30,00	3,0	18,00
1889	CAGIVA	25,00	3,2	16,00
2766	GAS-GAS	29,50	2,8	16,00
2767	GAS-GAS	30,00	3,2	16,00
2981	GAS-GAS	38,00	3,6	18,00
3195	GAS-GAS	28,00	0,0	15,00
3249	GAS-GAS	38,00	3,8	18,00
2088	HM	28,00	2,0	12,00
2227	HM	37,50	3,8	18,00
2783	HM	25,20	1,9	12,00
2151	HONDA	28,00	2,6	15,00
2153	HONDA	37,90	3,8	18,00
2189	HONDA	28,00	0,0	15,00
2190	HONDA	28,00	0,0	15,00
2358	HONDA	28,00	0,0	15,00
2387	HONDA	37,90	3,8	18,00
2446	HONDA	24,10	2,2	14,00
2447	HONDA	40,00	6,7	20,00
2454	HONDA	38,00	0,0	18,00
2455	HONDA	38,00	0,0	18,00
2458	HONDA	40,00	6,7	20,00
2499	HONDA	24,10	2,2	14,00
2548	HONDA	28,00	0,0	15,00
2581	HONDA	38,00	0,0	18,00
2653	HONDA	38,00	0,0	18,00
2685	HONDA	28,00	0,0	15,00
2687	HONDA	28,00	0,0	15,00
2689	HONDA	28,00	0,0	15,00
2809	HONDA	28,00	0,0	15,00
2810	HONDA	28,00	0,0	15,00
2811	HONDA	28,00	0,0	15,00
2863	HONDA	24,00	2,3	14,00
2995	HONDA	28,00	2,6	15,00
2996	HONDA	28,00	2,6	15,00
2997	HONDA	28,00	2,6	15,00
3133	HONDA	38,00	3,8	18,00
3137	HONDA	38,00	3,8	18,00
3138	HONDA	38,00	3,8	18,00
3140	HONDA	28,00	2,6	15,00
3265	HONDA	25,00	2,6	15,00
1757	HUSQ	30,00	3,0	18,00
1889	HUSQ	25,00	3,2	16,00
2132	HUSQ	25,00	0,0	16,00
2133	HUSQ	25,00	0,0	16,00
2203	HUSQ	25,00	0,0	16,00
2600	HUSQ	28,00	0,0	15,00

Codice pistone Piston part No.	Marca Make	Quota compressione compression height	Bombatura testa head	Diametro foro spinotto Pin diameter
CODICI PISTONI CROSS 2T / OFF ROAD 2STROKE REF. LIST				
2601	HUSQ	38,00	0,0	18,00
2244	KAWA	37,00	3,5	18,00
2245	KAWA	29,60	0,0	15,00
2248	KAWA	29,60	0,0	16,00
2306	KAWA	29,30	1,0	15,00
2445	KAWA	26,10	2,0	14,00
2498	KAWA	29,30	1,0	15,00
2502	KAWA	26,10	2,0	14,00
2509	KAWA	29,45	0,85	15,00
2521	KAWA	37,00	3,57	18,00
2525	KAWA	21,50	2,5	12,00
2550	KAWA	29,45	0,85	15,00
2578	KAWA	29,45	0,85	15,00
2579	KAWA	37,00	3,57	18,00
2644	KAWA	37,00	3,57	18,00
2712	KAWA	29,30	2,5	15,00
2714	KAWA	29,30	2,5	15,00
2716	KAWA	29,30	2,5	15,00
2795	KAWA	37,10	3,4	18,00
2797	KAWA	37,10	3,4	18,00
2799	KAWA	37,10	3,4	18,00
2803	KAWA	26,10	2,0	14,00
2853	KAWA	29,30	2,5	15,00
2860	KAWA	23,50	2,1	12,00
2875	KAWA	25,90	2,0	14,00
3004	KAWA	29,30	2,5	15,00
3124	KAWA	37,10	3,4	18,00
3125	KAWA	37,10	3,4	18,00
3126	KAWA	37,10	3,4	18,00
2171	KTM	21,50	2,5	12,00
2293	KTM	28,00	1,9	15,00
2295	KTM	28,00	0,0	15,00
2361	KTM	28,00	0,0	15,00
2367	KTM	21,50	2,5	12,00
2402	KTM	21,50	2,5	12,00
2442	KTM	29,80	3,6	18,00
2459	KTM	26,70	0,0	18,00
2481	KTM	21,50	2,5	12,00
2525	KTM	21,50	2,5	12,00
2532	KTM	28,00	0,0	15,00
2541	KTM	27,00	0,0	18,00
2649	KTM	38,00	0,0	18,00
2650	KTM	38,00	0,0	18,00
2813	KTM	21,50	2,5	12,00
2907	KTM	28,00	0,0	16,00
2909	KTM	38,00	3,7	18,00
2925	KTM	28,00	0,0	16,00



Codice pistone Piston part No.	Marca Make	Quota compressione compression height	Bombatura testa head	Diametro foro spinotto Pin diameter
CODICI PISTONI CROSS 2T / OFF ROAD 2STROKE REF. LIST				
2926	KTM	28,00	0,0	16,00
2991	KTM	24,00	2,2	14,00
2992	KTM	38,00	0,0	18,00
3121	KTM	38,00	3,7	18,00
3238	KTM	38,00	3,7	18,00
3294	KTM	24,00	2,2	14,00
3330	KTM	29,50	0,00	15,00
3331	KTM	29,50	0,00	15,00
3383 / 3384	KTM	29,50	0,00	15,00
2623	SHERCO	28,50	3,0	16,00
2624	SHERCO	28,50	3,2	16,00
2625	SHERCO	29,00	4,5	18,00
2674	SHERCO	27,80	3,7	18,00
2860	SUZUKI	23,50	2,1	12,00
2444	SUZUKI	27,00	1,9	14,00
2215	SUZUKI	37,00	4,8	18,00
2216	SUZUKI	29,60	2,4	15,00
2360	SUZUKI	29,60	2,4	15,00
2382	SUZUKI	29,60	0,0	15,00
2386	SUZUKI	38,00	3,7	18,00
2501	SUZUKI	27,00	1,9	14,00
2540	SUZUKI	38,00	0,0	18,00
2551	SUZUKI	29,60	2,4	15,00
2585	SUZUKI	38,00	3,7	18,00
2592	SUZUKI	38,00	3,7	18,00
2642	SUZUKI	29,50	2,5	15,00
2643	SUZUKI	29,50	2,5	15,00
2646	SUZUKI	38,00	0,0	18,00
2647	SUZUKI	38,00	0,0	18,00
2648	SUZUKI	38,00	0,0	18,00
2652	SUZUKI	29,50	2,5	15,00
2854	SUZUKI	38,20	3,4	18,00
2855	SUZUKI	38,20	3,4	18,00
2856	SUZUKI	38,20	3,4	18,00
2877	SUZUKI	27,00	2,0	14,00
2880	SUZUKI	27,00	2,0	14,00
2882	SUZUKI	23,60	1,9	12,00
2998	SUZUKI	29,50	0,0	15,00
2999	SUZUKI	29,50	0,0	15,00
3001	SUZUKI	29,50	0,0	15,00
2389	TM	29,00	2,0	15,00
2654	TM	37,90	3,8	18,00
3249	TM	38,00	3,8	18,00
2152	YAMAHA	28,00	0,0	16,00
2154	YAMAHA	36,00	3,0	18,00
2224	YAMAHA	28,00	2,6	16,00
2226	YAMAHA	36,00	3,0	18,00

Codice pistone Piston part No.	Marca Make	Quota compressione compression height	Bombatura testa head	Diametro foro spinotto Pin diameter
CODICI PISTONI CROSS 2T / OFF ROAD 2STROKE REF. LIST				
2356	YAMAHA	36,00	3,0	18,00
2359	YAMAHA	28,00	2,6	16,00
2441	YAMAHA	28,00	2,5	15,00
2443	YAMAHA	26,00	2,1	14,00
2452	YAMAHA	28,00	2,5	15,00
2500	YAMAHA	26,00	2,1	14,00
2520	YAMAHA	28,00	2,5	15,00
2522	YAMAHA	36,00	3,0	18,00
2549	YAMAHA	28,00	2,5	15,00
2577	YAMAHA	28,00	2,5	15,00
2584	YAMAHA	37,90	3,5	18,00
2591	YAMAHA	37,90	3,5	18,00
2645	YAMAHA	37,90	3,5	18,00
2806	YAMAHA	28,00	2,5	15,00
2807	YAMAHA	28,00	2,5	15,00
2808	YAMAHA	28,00	2,5	15,00
2868	YAMAHA	26,00	2,1	14,00
2871	YAMAHA	26,00	2,1	14,00
3119	YAMAHA	27,40	0,6	15,00
3120	YAMAHA	27,40	0,6	15,00
3335	YAMAHA	28,00	0,5	15,00

CODICI PISTONI KART / KART PISTONS REF. LIST				
1842	ROTAX	29,00	3,3	15,00
2427	ROTAX	26,00	4,1	14,00
2428	ROTAX	26,00	2,0	15,00
2434	ROTAX	29,00	2,0	15,00
3250	ROTAX	29,00	3,3	15,00
2602	IAME/COMER	26,00	4,1	14,00
2691	IAME	30,00	3,8	14,00
2815	IAME/COMER	26,00	4,1	14,00
2817	IAME/COMER	26,00	4,1	14,00
3248	VORTEX	29,50	4,5	14,00

CODICI PISTONI SCOOTER / SCOOTERS PISTONS REF. LIST				
1842	APRILIA	29,00	3,3	15,00
1938	APRILIA	29,00	3,3	15,00
1988	APRILIA	27,50	1,6	12,00
2003	APRILIA	29,00	3,3	15,00
2032	APRILIA	25,60	2,3	10,00
2061	APRILIA	25,80	2,4	12,00
2088	APRILIA	28,00	2,0	12,00
2261	APRILIA	29,00	3,3	15,00
2796	APRILIA	28,50	0,0	16,00
2800	APRILIA	28,50	0,0	16,00
2944	APRILIA	24,00	2,0	15,00



Codice pistone Piston part No.	Marca Make	Quota compressione compression height	Bombatura testa head	Diametro foro spinotto Pin diameter
CODICI PISTONI SCOOTER / SCOOTERS PISTONS REF.LIST				
3091	APRILIA	24,00	2,0	15,00
3202	APRILIA	27,00	2,5	12,00
3372	APRILIA	25,80	2,4	12,00
2525	BETA	21,50	2,5	12,00
2087	CAGIVA	25,00	3,2	16,00
2117	CAGIVA	25,00	0,0	16,00
2362	DR	25,50	2,5	12,00
2372	DR	25,50	2,4	10,00
2374	DR	23,00	2,5	12,00
2138	DERBI	19,00	3,44	10,00
2775	DERBI	24,10	2,0	12,00
3359	DERBI	24,10	2,0	12,00
2013	GILERA	33,00	3,0	16,00
2033	GILERA	23,50	2,15	12,00
2061	GILERA	25,80	2,4	12,00
2341	GILERA	33,00	3,0	16,00
1725	HONDA	30,50	2,6	16,00
1972	HONDA	30,00	2,3	16,00
2023	HONDA	25,00	2,7	10,00
2024	HONDA	20,00	2,7	10,00
2030	HONDA	25,00	2,4	12,00
2082	HONDA	25,20	2,55	10,00
2175	HONDA	30,00	2,5	14,00
2383	HONDA	28,00	2,3	12,00
2429	HONDA	29,00	2,4	15,00
3105	HONDA	29,00	2,5	15,00
3224	HONDA	29,00	0,0	15,00
2221	KIMCO	28,00	2,3	12,00
2383	KIMCO	28,00	2,3	12,00
2351	MALOSSI	24,80	3,1	10,00
2352	MALOSSI	24,80	3,1	12,00
2353	MALOSSI	24,80	3,1	10,00
2354	MALOSSI	24,80	3,1	12,00
2606	MALOSSI	24,80	3,0	12,00
1809	MINARELLI	28,00	2,0	12,00
2032	MINARELLI	25,60	2,3	10,00
2060	MINARELLI	28,00	2,0	12,00
2062	MINARELLI	28,00	2,0	12,00
2088	MINARELLI	28,00	2,0	12,00
1820	MORINI F.	28,50	2,5	12,00
1821	MORINI F.	28,50	2,5	12,00
2016	MORINI F.	22,00	2,5	12,00
2039	MORINI F.	28,00	3,5	12,00
2138	MORINI F.	19,00	3,44	10,00
2160	MORINI F.	28,00	3,5	12,00

Codice pistone Piston part No.	Marca Make	Quota compressione compression height	Bombatura testa head	Diametro foro spinotto Pin diameter
CODICI PISTONI SCOOTER / SCOOTERS PISTONS REF.LIST				
2618	MORINI F.	23,50	2,15	12,00
2619	MORINI F.	23,50	2,15	12,00
2023	PEUGEOT	25,00	2,7	10,00
2024	PEUGEOT	20,00	2,7	10,00
2313	PEUGEOT	21,50	3,0	12,00
915	PIAGGIO	26,00	4,0	12,00
1076	PIAGGIO	42,50	5,5	16,00
1433	PIAGGIO	26,50	4,0	12,00
1604	PIAGGIO	35,50	5,5	15,00
1634	PIAGGIO	26,50	3,7	10,00
1640	PIAGGIO	43,00	5,0	16,00
1659	PIAGGIO	36,50	5,5	15,00
1660	PIAGGIO	35,00	7,3	15,00
1931	PIAGGIO	26,00	4,0	12,00
1962	PIAGGIO	42,50	5,6	18,00
2061	PIAGGIO	25,80	2,4	12,00
2249	PIAGGIO	29,50	3,6	12,00
2339	PIAGGIO	30,00	4,2	16,00
2392	PIAGGIO	30,00	4,2	16,00
1624	POLINI	26,50	2,2	12,00
1635	POLINI	36,00	4,0	15,00
1744	POLINI	26,00	4,0	12,00
2134	POLINI	28,00	2,0	12,00
2262	POLINI	26,50	3,0	12,00
2273	POLINI	26,50	3,0	12,00
2274	POLINI	24,60	2,35	10,00
2275	POLINI	24,60	2,35	10,00
2423	POLINI	24,50	1,85	12,00
2424	POLINI	24,50	1,75	12,00
2425	POLINI	24,50	2,35	10,00
2560	POLINI	25,00	2,0	10,00
2561	POLINI	25,00	2,0	12,00
2138	SUZUKI	19,00	3,44	10,00
2491	SUZUKI	27,00	3,5	12,00
2796	SUZUKI	28,50	0,0	16,00
2800	SUZUKI	28,50	0,0	16,00
2383	SYM	28,00	2,3	12,00
2362	TOP. PERF.	25,50	2,5	12,00
2372	TOP. PERF.	25,50	2,4	10,00
2373	TOP. PERF.	25,50	2,4	10,00
2374	TOP. PERF.	23,00	2,5	12,00
2081	YAMAHA	25,00	2,8	10,00
2138	YAMAHA	19,00	3,44	10,00
2140	YAMAHA	30,00	3,1	16,00
2222	YAMAHA	23,00	2,0	12,00



2 Stroke

After disassembling the cylinder head and the cylinder, it's necessary to measure the actual cylinder diameter (1), using a dial bore gauge. When actual bore size is known then it is time to pick the right VERTEX piston to fit your bore size, respecting the clearance suggested with the cylinder (i.e. CR 125 clearance 0.05 mm).

Open the piston box, take the ring and position it inside the cylinder bore. Measure the gap (2) between the two ring ends: it must be between a minimum of 0.25 and a maximum of 0.50 mm; if necessary adjust the ring end gap dimension using a file (3). Take special care when performing this step.

We are now ready to assemble the ring into the piston groove: first of all pay attention to not crush or damage the ring during installation, every precaution should be taken not to compromise the ring integrity with the groove and to not reduce the rings retaining pressure.

Attention must be paid to any markings (i.e. T) on the rings surface: always position the ring with the written part on the top side.

Introduce before the ring from the side opposite to the locating pin and turning it as it was a spring taking care to not damage the groove during the operation. After verifying that the rings do not have strange creeping or binding, position the ring tips around the locating pin.

We are now ready to assemble the piston and cylinder. A light coating of two stroke oil should be applied to the piston with the ring(s) assembled. Position the arrow printed on the piston dome toward the exhaust side, install one circlip on the opposite side you will slide the pin thru and pressing the ring (or the rings) into the groove one by one starting from the top slide the cylinder assembly over the rings. When this is complete carefully lower piston and cylinder onto the connecting rod and slide piston pin thru piston and rod and install circlip. If you prefer you may install piston onto connecting rod first and then compress ring(s) and install cylinder (4).

Assemble cylinder onto cases and install cylinder head and torque all fasteners to the recommended specs in your owner's manual.

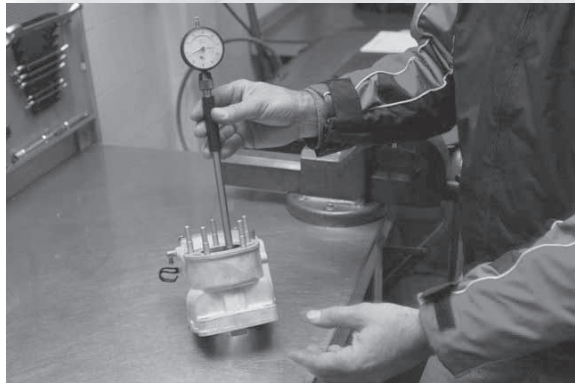

(1)

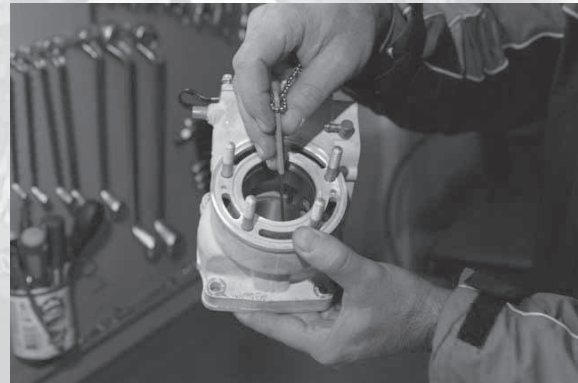

(2)



(3)

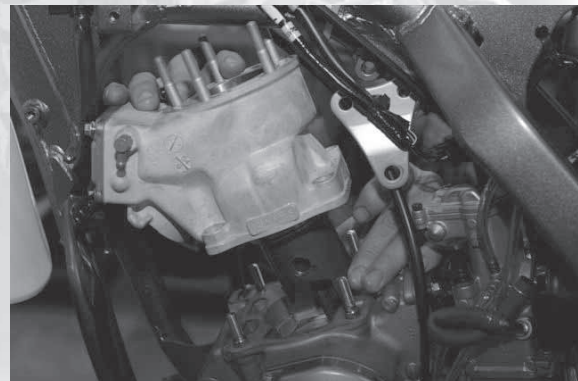

(4)